

# Y STRAINER

## Y 型過濾器 PVC 1/2" ~ 2"

### DATA

- Working pressure : 150 PSI / 73° F
- EPDM or FPM seat
- PP FILTER
- Brand: SUPERTUNG



No	PARTS NAME	Q'TY	MATERIAL
1	BODY	1	PVC
2	CARRY	1	PVC
3	FILTER	1	PP
4	CAP	1	ABS
5	O-RING	1	EPDM,FPM
6	NUT	2	PVC,CPVC
7	CONNECTOR	2	PVC,CPVC
8	O-RING	2	EPDM,FPM

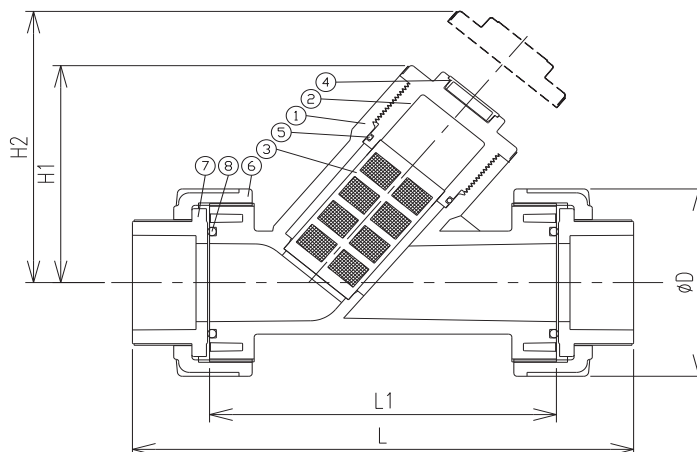

SIZE	D	L	ANSI		DIN		JIS		CNS		NPT	BSPT	BSPF	H1	H2	L1
			Øde	I	Øde	I	Øde	I	Øde	I						
1/2" (15mm)	56	171	21.34	22.5	20	20	22	22.5	22	22.5	14	14	14	85	130	110
3/4" (20mm)	56	172	26.67	25.7	25	23	26	25.7	26	25.7	14	14	14	85	130	110
1" (25mm)	66	197	33.4	28.9	32	26	32	28.9	34	28.9	11.5	11	11	92	150	126
1-1/4" (32mm)	98	254	42.16	33.8	40	31	38	33.8	42	33.8	11.5	11	11	122	205	173
1-1/2" (40mm)	98	254	48.26	35	50	34	48	35	48	35	11.5	11	11	122	205	173
2" (50mm)	120	297	60.32	38.5	63	38.5	60	38.5	60	38.5	11.5	11	11	141	230	204

## Technical Information

Item	Description	Size	Material	
			Body	O-ring
(1)	Y Strainer	1/2" (DN15)	PVC	EPDM,FPM
(2)	Y Strainer	3/4" (DN20)	PVC	EPDM,FPM
(3)	Y Strainer	1" (DN25)	PVC	EPDM,FPM
(4)	Y Strainer	1-1/4" (DN32)	PVC	EPDM,FPM
(5)	Y Strainer	1-1/2" (DN40)	PVC	EPDM,FPM
(6)	Y Strainer	2" (DN50)	PVC	EPDM,FPM

Size	Hydrostatic Testing		O-ring tests air(kgf/cm <sup>2</sup> )	Cv
	Burst pressure water (kgf/cm <sup>2</sup> ) minimun	Long-term behaviour test water (kgf/cm <sup>2</sup> )		
1/2" (DN15)	31	22	6	4
3/4" (DN20)	31	22	6	6.8
1" (DN25)	31	22	6	9
1-1/4" (DN32)	31	22	6	12
1-1/2" (DN40)	31	22	6	28
2" (DN50)	31	22	6	28

## Working pressure vs. Temperature

