

ASAHI

DIAPHRAGM VALVE

- P.015 DIAPHRAGM VALVE TYPE 14
- P.021 TRUE UNION DIAPHRAGM VALVE TYPE 14
- P.025 DIAPHRAGM VALVE TYPE 15
- P.031 DIAPHRAGM VALVE TYPE 72
- P.035 DIAPHRAGM VALVE TYPE AI
- P.035 TRUE UNION DIAPHRAGM VALVE TYPE AI
- P.037 DIAPHRAGM VALVE TYPE 16
- P.039 OPTIONS



DIAPHRAGM VALVE LINEUP **AUTOMATIC**

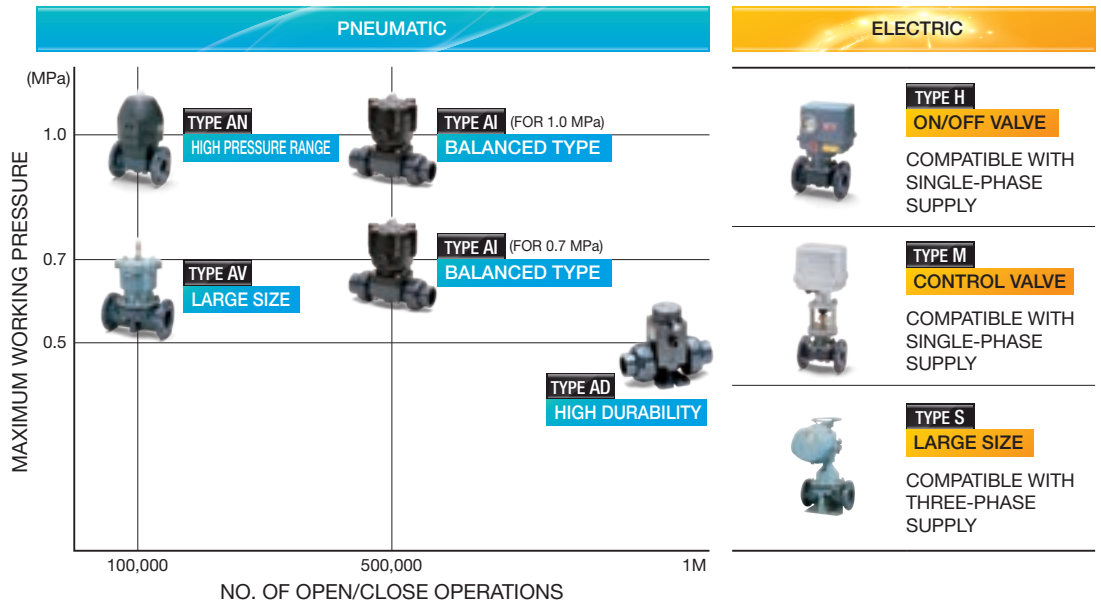

AVAILABLE OPTIONS **AUTOMATIC** * Options other than those listed below are also available. Contact us for inquiry.

	PNEUMATIC				ELECTRIC		
	TYPE AN	TYPE AI	TYPE AD	TYPE AV	TYPE H	TYPE M	TYPE S
SOLENOID VALVE	●	●		●			
FILTER REGULATOR	●	●		●			
SPEED CONTROLLER	●	●	●	●			
BYPASS VALVE	●	●		●			
LIMIT SWITCH	●	●	*	●			
OUTPUT CONTACT LIMIT SWITCH					STANDARD		●
E/P POSITIONER	●	●		●			
P/P POSITIONER	●	●		●			
E/E POSITIONER						STANDARD	●
MANUAL OVERRIDE	●	●		●	STANDARD	STANDARD	STANDARD
FULL OPENING ADJUSTMENT	●	●	● INDICATOR PROVIDED	●			
SPACE HEATER					STANDARD		STANDARD
POTENTIOMETER					●		●
R/I TRANSMITTER							●
SPECIAL PAINTING (ACTUATOR ONLY)				●	●	●	●
METAL INSERT PROVIDED (WITH ENSAT)	●	●		● UP TO 100A	●	●	

* For information about the support for the limit switch (micro switch), contact us.



SOLENOID VALVE



SPEED CONTROLLER



LIMIT SWITCH



E/P POSITIONER



FULL OPENING ADJUSTMENT

DIAPHRAGM VALVE TYPE 14

- NEAR-LINEAR FLOW CHARACTERISTICS
- A NEW TYPE OF RUBBER HAVING A HIGH RELIABILITY IN LEAKAGE PREVENTION IS USED FOR THE DIAPHRAGM AND CUSHION.
- THE ORIGINAL DESIGN ACHIEVES HIGH SEALING PERFORMANCE WITH LOW TORQUE.
- BAYONET STRUCTURE ALLOWING QUICK DIAPHRAGM REPLACEMENT
- EQUIPPED WITH A BOTTOM STAND ALLOWING EASY AND SECURE REPLACEMENT (See P. 69 for details.)

BASIC SPECIFICATIONS

VALVE TYPE ————— **DIAPHRAGM VALVE TYPE 14**

SIZE ————— **15 mm—100 mm (1/2 inch—4 inch)**

BODY MATERIAL ————— **U-PVC C-PVC PP PVDF**

SEAL MATERIAL / DIAPHRAGM ————— **EPDM PTFE FKM etc.**

CONNECTION / FLANGED ————— **JIS10K, DIN PN10, ANSI CLASS150**

	FLUID TEMPERATURE	MAXIMUM WORKING PRESSURE (NORMAL TEMPERATURE) MPa(kgf/cm ²)	CONNECTION METHOD
			FLANGED
U-PVC	0°C ~ 60°C	1.0 {10.2}	○
C-PVC	0°C ~ 90°C	1.0 {10.2}	○
PP	-20°C ~ 90°C	1.0 {10.2}	○
PVDF	-40°C ~ 120°C	1.0 {10.2}	○

NOTE The maximum working pressure is the value including the water hammer pressure. Be careful that the maximum working pressure is not exceeded during use.
 * Concerning the allowable pressure for each temperature and material, see the technical documents at the end of this catalog.
 * The diaphragm may become loose due to temperature changes during long storage, operation stop or while in use. Check the conditions and then retighten the bolts and nuts between the bonnet and the body to the "bonnet tightening torque". (Failure to do so may cause fluid leakage.)

MANUAL



AUTOMATIC



PARTS LIST **MANUAL**

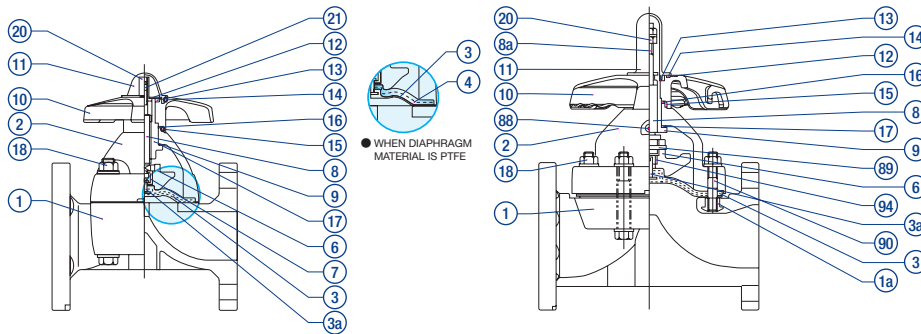

PART NO. / NAME	QTY	MATERIAL	PART NO. / NAME	QTY	MATERIAL	PART NO. / NAME	QTY	MATERIAL
① BODY	1	BODY — BONNET U-PVC — U-PVC C-PVC — PP PP — PP PVDF — PPG ⁽¹⁾ PVDF — PVDF	⑧ STEM	1	C3604	⑰ THRUST RING (B)	1	UHMWPE
② BONNET	1		⑧a DISPLAY LOT ⁽⁴⁾	1	SUS304	⑱ BOLT/NUT (A)	4	SUS304
③ DIAPHRAGM	1	EPDM, PTFE, etc.	⑨ SLEEVE	1	C3604	⑳ STOPPER	1	C3604 ⁽³⁾ , SUS304 ⁽⁴⁾
③a EMBEDDED DIAPHRAGM FITTING	1	SUS304	⑩ HANDLE	1	PP	㉑ SCREW ⁽³⁾	1	SUS304
④ CUSHION ⁽²⁾	1	EPDM	⑪ GAUGE COVER	1	PC	㉒ GREASE NIPPLE ⁽⁴⁾	1	C3604
⑤ COMPRESSOR	1	PVDF	⑫ NAMEPLATE	1	U-PVC	㉓ COMPRESSOR PIN ⁽⁴⁾	1	SUS304
⑦ JOINT FITTING ⁽³⁾	1	SUS304	⑬ C-SHAPED STOP RING	1	SUS304	⑳ STUD BOLT/NUT ⁽⁴⁾	4	SUS304
			⑭ O-RING (A)	1	EPDM	㉔ COMPRESSOR	1	SUS304
			⑮ O-RING (B)	1	EPDM	㉕ STUD NUT ⁽⁴⁾	4	C3604 ⁽⁵⁾ , SUS304 ⁽⁶⁾
			⑯ THRUST RING (A)	1	UHMWPE			

NOTE (1) Bonnet PPG 15 – 100 mm: black. 125 – 250 mm: ivory. (2) is used when the diaphragm material is PTFE. (3) is used for sizes of 50 mm or less. (4) is used for sizes of 65 mm or more. (5) is used when the body material is U-PVC, C-PVC or PP. (6) is used when the body material is PVDF.

HANDLE ROTATION [FULL OPEN (ROTATION/LIFT) FULL CLOSE] **MANUAL**

SIZE	ROTATION	SIZE	ROTATION
15mm (1/2inch)	3.3	50mm (2inch)	6.0
20mm (3/4inch)	3.3	65mm (2 1/2inch)	9.0
25mm (1inch)	4.0	80mm (3inch)	10.0
32mm (1 1/4inch)	4.0	100mm (4inch)	10.0
40mm (1 1/2inch)	5.0		

COMPATIBLE ACTUATOR **AUTOMATIC**

PNEUMATIC	TYPE AN	For detailed specifications, see P.117	ELECTRIC	TYPE H	For detailed specifications, see P.125
PNEUMATIC	TYPE AV	For detailed specifications, see P.118	ELECTRIC	TYPE M	For detailed specifications, see P.127

PRODUCT MODEL CODE LIST
MANUAL

ACTUATION	TYPE	OPERATING SYSTEM	BODY MATERIAL	SEAL MATERIAL	CONNECTION	STANDARD	SIZE				
V	14	MH	*	*	F	*	***				
⋮	⋮	⋮	⋮	⋮	⋮	⋮	⋮				
V	MANUAL VALVE	14	TYPE 14	MH	ROUND HANDLE	U U-PVC C C-PVC P PP F PVDF G PVDF+PPG	E EPDM T PTFE	F	FLANGED	1 JIS10K D DIN A ANSI	015 15mm 100 100mm

PRODUCT MODEL CODE LIST
AUTOMATIC

ACTUATION	TYPE	ACTUATOR TYPE	ACTION / POWER SOURCE	BODY MATERIAL	SEAL MATERIAL	CONNECTION	STANDARD	SIZE			
A	14	*	*	*	*	F	*	***			
⋮	⋮	⋮	⋮	⋮	⋮	⋮	⋮	⋮			
A	AUTOMATIC VALVE	14	TYPE 14	PNEUMATIC N TYPE AN V TYPE AV ELECTRIC H TYPE H M TYPE M	PNEUMATIC F DOUBLE ACTING G AIR TO OPEN S AIR TO CLOSE ELECTRIC 1 Single-Phase 100V 2 Single-Phase 200V D DC24V	U U-PVC C C-PVC P PP F PVDF	E EPDM T PTFE	F	FLANGED	1 JIS10K D DIN A ANSI	015 15mm 100 100mm

MANUAL

DIAPHRAGM VALVE TYPE 14

TYPE—V14MH

CONNECTION / FLANGED—JIS, DIN, ANSI

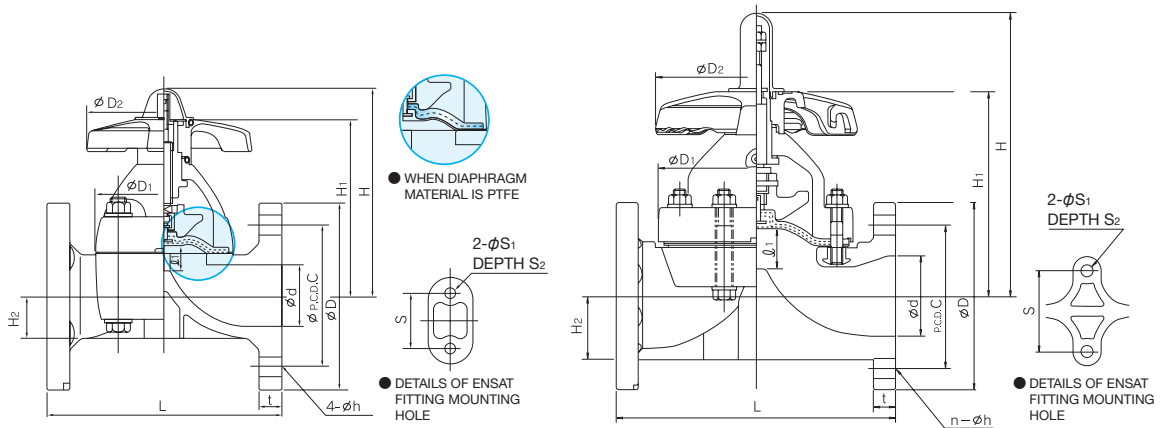

■ JIS, DIN (Unit: mm)

mm	d	D1	D2	ℓ1	H	H1	H2	S	S1	S2	JIS10K						DIN PN10							
											D	C	n	h	L	U-PVC C-PVC	PP PVDF	D	C	n	h	L	U-PVC C-PVC	PP PVDF
15	16	54×66	100	10	104	86	19.5	25	7	13	95	70	4	15	110	12	12	95	65	4	14	130	12	12
20	20	54×66	100	10	106	88	17.5	25	7	13	100	75	4	15	120	13	13	105	75	4	14	150	13	13
25	25	67×80	100	12	111	93	18.5	25	7	13	125	90	4	19	130	13	13	115	85	4	14	160	13	13
32	32	67×80	100	12	116	97	22.5	25	7	13	135	100	4	19	142	16	16	140	100	4	18	180	16	16
40	40	108×108	156	21	177	144	27.5	45	9	15	140	105	4	19	180	16	16	150	110	4	18	200	20	20
50	52	123×123	156	25	191	158	36.0	45	9	15	155	120	4	19	210	20	20	165	125	4	18	230	22	22
65	67	175	220	34	266	188	61	85	11	20	175	140	4	19	250	22	23	185	145	4	18	290	22	22
80	78	201	220	42	280	202	63	100	15	28	185	150	8	19	280	22	23	200	160	8	18	310	24	24
100	100	241	257	50	329	241	78	120	15	28	210	175	8	19	340	22	24	220	180	8	18	350	24	26

■ ANSI (Unit: inch)

inch	mm	d	D1	D2	ℓ1	H	H1	H2	S	S1	S2	ANSI CLASS150										
												D	C	n	h	L	GRINNELL STANDARD	AV STANDARD	U-PVC C-PVC	PP PVDF		
1/2	15	0.63	2.13×2.60	3.94	0.39	4.09	3.39	0.77	0.98	0.28	0.51	3.50	2.38	4	0.62	4.25	4.33	0.43	0.43			
3/4	20	0.79	2.13×2.60	3.94	0.39	4.17	3.46	0.69	0.98	0.28	0.51	3.88	2.75	4	0.62	5.88	4.72	0.51	0.51			
1	25	0.98	2.64×3.15	3.94	0.47	4.37	3.66	0.73	0.98	0.28	0.51	4.25	3.12	4	0.62	5.88	5.12	0.59	0.59			
1 1/4	32	1.26	2.64×3.15	3.94	0.47	4.57	3.82	0.89	0.98	0.28	0.51	4.62	3.50	4	0.62	6.38	-	0.63	0.63			
1 1/2	40	1.57	4.25×4.25	6.14	0.83	6.97	5.67	1.08	1.77	0.35	0.59	5.00	3.88	4	0.62	6.94	7.09	0.63	0.63			
2	50	2.05	4.84×4.84	6.14	0.98	7.52	6.22	1.42	1.77	0.35	0.59	6.00	4.75	4	0.75	7.94	8.27	0.79	0.79			
2 1/2	65	2.64	6.89	8.66	1.34	10.47	7.40	2.40	3.35	0.43	0.79	7.00	5.50	4	0.75	-	9.84	0.87	0.91			
3	80	3.07	7.91	8.66	1.65	11.02	7.95	2.48	3.94	0.59	1.10	7.50	6.00	4	0.75	10.37	11.02	0.87	0.91			
4	100	3.94	9.49	10.12	1.97	12.95	9.49	3.07	4.72	0.59	1.10	9.00	7.50	8	0.75	12.93	13.39	0.87	0.94			

AUTOMATIC PNEUMATIC TYPE AN
DOUBLE ACTING
AIR TO OPEN
AIR TO CLOSE

DIAPHRAGM VALVE TYPE 14

TYPE—A14N
 CONNECTION / FLANGED—JIS, DIN, ANSI

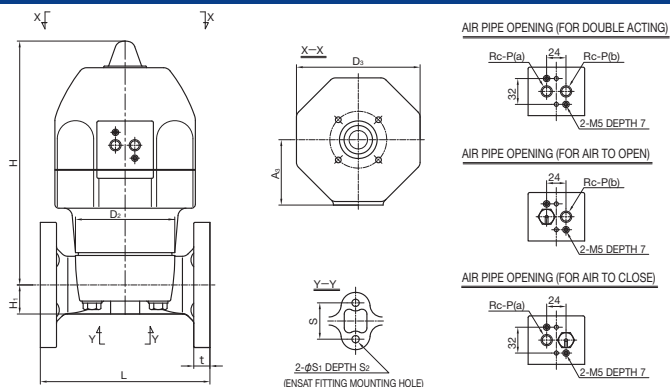

ACTUATOR SELECTION CHART

SIZE	ACTUATOR TYPE		
	DOUBLE ACTING	AIR TO OPEN	AIR TO CLOSE
15mm (1/2inch)	AN-1DA	AN-1AO	AN-1AS
20mm (3/4inch)	AN-2DA	AN-2AO	AN-2AS
25mm (1inch)	AN-3DA	AN-3AO	AN-3AS
32mm (1 1/4inch)	AN-4DA	AN-4AO	AN-4AS
40mm (1 1/2inch)	AN-3DA	AN-3AO	AN-3AS
50mm (2inch)	AN-4DA	AN-4AO	AN-4AS

For detailed specifications, see P.117

■ JIS, DIN (Unit: mm)

mm	D ₂	D ₃	H	H ₁	A ₃	S	S ₁	S ₂	P	JIS10K		DIN PN10	
										L	t	L	t
15	54×66	130	186	19.5	68	25	7	13	1/4	110	12	130	12
20	54×66	130	188	17.5	68	25	7	13	1/4	120	13	150	13
25	67×80	130	193	18.5	68	25	7	13	1/4	130	13	160	13
32	67×80	130	197	22.5	68	25	7	13	1/4	142	16	180	16
40	108×108	174	293	27.5	92	45	9	15	1/4	180	16	200	20
50	123×123	174	302	36	92	45	9	15	1/4	210	20	230	22

■ ANSI (Unit: inch)

inch	mm	D ₂	D ₃	H	H ₁	A ₃	S	S ₁	S ₂	P	ANSI CLASS150		
											L	AV STANDARD	t
1/2	15	2.13×2.60	5.12	7.32	0.77	2.68	0.98	0.28	0.51	1/4	4.25	4.33	0.43
3/4	20	2.13×2.60	5.12	7.40	0.69	2.68	0.98	0.28	0.51	1/4	5.88	4.72	0.51
1	25	2.64×3.15	5.12	7.60	0.73	2.68	0.98	0.28	0.51	1/4	5.88	5.12	0.59
1 1/4	32	2.64×3.15	5.12	7.76	0.89	2.68	0.98	0.28	0.51	1/4	6.38	-	0.63
1 1/2	40	4.25×4.25	6.85	11.54	1.08	3.62	1.77	0.35	0.59	1/4	6.94	7.09	0.63
2	50	4.84×4.84	6.85	11.89	1.42	3.62	1.77	0.35	0.59	1/4	7.94	8.27	0.79

AUTOMATIC PNEUMATIC TYPE AV
DOUBLE ACTING
AIR TO OPEN
AIR TO CLOSE

DIAPHRAGM VALVE TYPE 14

TYPE—A14V
 CONNECTION / FLANGED—JIS, DIN, ANSI

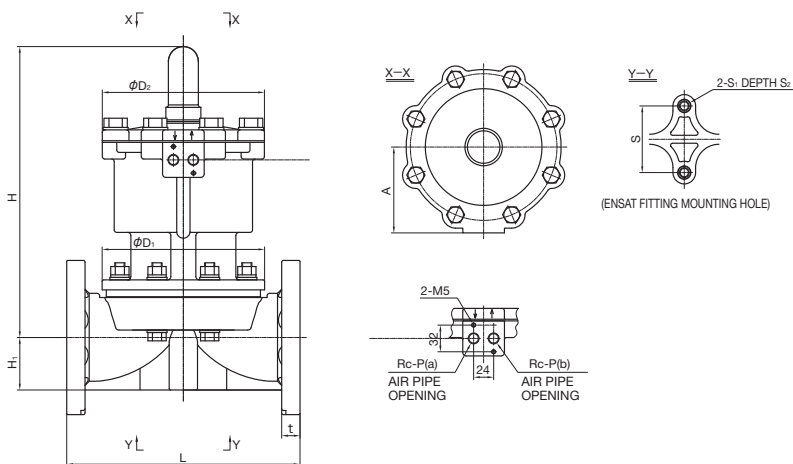

ACTUATOR SELECTION CHART

SIZE	ACTUATOR TYPE
65mm (2 1/2inch)	AV-1DA
80mm (3inch)	AV-2DA
100mm (4inch)	AV-3DA

For detailed specifications, see P.118

■ JIS, DIN (Unit: mm)

mm	D ₁	D ₂	A	H	H ₁	S	S ₁	S ₂	P	JIS10K			DIN PN10		
										L	U-PVC C-PVC	PP PVDF	L	U-PVC C-PVC	PP PVDF
65	171	208	103	323	61	85	M8	15	1/4	250	22	23	290	22	22
80	195	208	103	354	63	100	M12	22	1/4	280	22	23	310	24	24
100	235	250	120	417	78	120	M12	22	1/4	340	22	24	350	24	26

■ ANSI (Unit: inch)

inch	mm	D ₁	D ₂	A	H	H ₁	S	S ₁	S ₂	P	ANSI CLASS150			
											L	AV STANDARD	U-PVC C-PVC	PP PVDF
2 1/2	65	6.73	8.19	4.06	12.72	2.40	3.35	M8	0.59	1/4	-	9.84	0.87	0.91
3	80	7.68	8.19	4.06	13.94	2.48	3.94	M12	0.87	1/4	10.37	11.02	0.87	0.91
4	100	9.25	9.84	4.72	16.42	3.07	4.72	M12	0.87	1/4	12.93	13.39	0.87	0.94

AUTOMATIC

PNEUMATIC

TYPE AV

DOUBLE ACTING

AIR TO OPEN

AIR TO CLOSE

DIAPHRAGM VALVE TYPE 14

TYPE—A14V

CONNECTION / FLANGED—JIS, DIN, ANSI

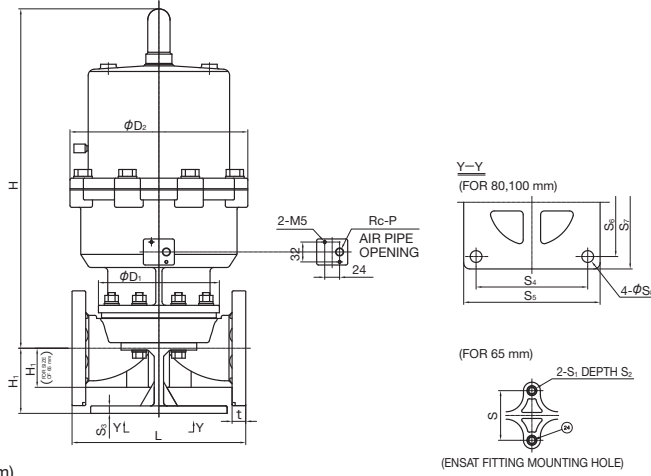

ACTUATOR SELECTION CHART

SIZE	ACTUATOR TYPE
65mm (2 1/2inch)	AV-1AO
80mm (3inch)	AV-2AO
100mm (4inch)	AV-3AO

For detailed specifications, see **P.118**

■ JIS, DIN (Unit: mm)

mm	D ₁	D ₂	H	H ₁	S	S ₁	S ₂	S ₃	S ₄	S ₅	S ₆	S ₇	S ₈	P	JIS10K			DIN PN10		
															L	t	U-PVC C-PVC	PP PVDF	L	t
65	171	280	473	61	85	M8	15	-	-	-	-	-	-	1/4	250	22	23	290	22	22
80	195	305	550	109	-	-	-	12	180	220	175	215	19	1/4	280	22	23	310	24	24
100	235	385	601	119	-	-	-	15	230	270	220	260	19	1/4	340	22	24	350	24	26

■ ANSI (Unit: inch)

inch	mm	D ₁	D ₂	H	H ₁	S	S ₁	S ₂	S ₃	S ₄	S ₅	S ₆	S ₇	S ₈	P	ANSI CLASS150				
																L	t	GRINNELL STANDARD	AV STANDARD	U-PVC C-PVC
2 1/2	65	6.73	11.02	18.62	2.40	3.35	M8	0.59	-	-	-	-	-	-	1/4	-	-	9.84	0.87	0.91
3	80	7.68	12.01	21.65	4.29	-	-	-	0.47	7.09	8.66	6.89	8.46	0.75	1/4	10.37	11.02	0.87	0.91	
4	100	9.25	15.16	23.66	4.69	-	-	-	0.59	9.06	10.63	8.66	10.24	0.75	1/4	12.93	13.39	0.87	0.94	

AUTOMATIC

PNEUMATIC

TYPE AV

DOUBLE ACTING

AIR TO OPEN

AIR TO CLOSE

DIAPHRAGM VALVE TYPE 14

TYPE—A14V

CONNECTION / FLANGED—JIS, DIN, ANSI

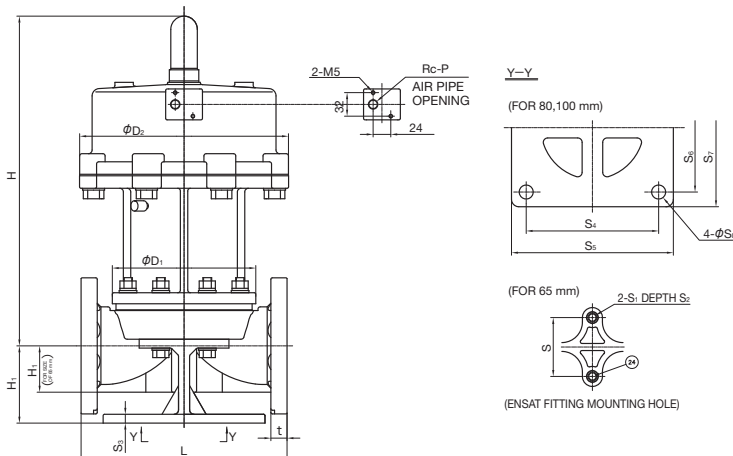

ACTUATOR SELECTION CHART

SIZE	ACTUATOR TYPE
65mm (2 1/2inch)	AV-1AS
80mm (3inch)	AV-2AS
100mm (4inch)	AV-3AS

For detailed specifications, see **P.118**

■ JIS, DIN (Unit: mm)

mm	D ₁	D ₂	H	H ₁	S	S ₁	S ₂	S ₃	S ₄	S ₅	S ₆	S ₇	S ₈	P	JIS10K			DIN PN10		
															L	t	U-PVC C-PVC	PP PVDF	L	t
65	171	280	423	61	85	M8	15	-	-	-	-	-	-	1/4	250	22	23	290	22	22
80	195	305	455	109	-	-	-	12	180	220	175	215	19	1/4	280	22	23	310	24	24
100	235	385	582	119	-	-	-	15	230	270	220	260	19	1/4	340	22	24	350	24	26

■ ANSI (Unit: inch)

inch	mm	D ₁	D ₂	H	H ₁	S	S ₁	S ₂	S ₃	S ₄	S ₅	S ₆	S ₇	S ₈	P	ANSI CLASS150				
																L	t	GRINNELL STANDARD	AV STANDARD	U-PVC C-PVC
2 1/2	65	6.73	11.02	16.65	2.40	3.35	M8	0.59	-	-	-	-	-	-	1/4	-	-	9.84	0.87	0.91
3	80	7.68	12.01	17.91	4.29	-	-	-	0.47	7.09	8.66	6.89	8.46	0.75	1/4	10.37	11.02	0.87	0.91	
4	100	9.25	15.16	22.91	4.69	-	-	-	0.59	9.06	10.63	8.66	10.24	0.75	1/4	12.93	13.39	0.87	0.94	

AUTOMATIC **ELECTRIC** **TYPE H** Single-Phase 100V
Single-Phase 200V

DIAPHRAGM VALVE TYPE 14

TYPE—A14H
CONNECTION / FLANGED—JIS, DIN, ANSI

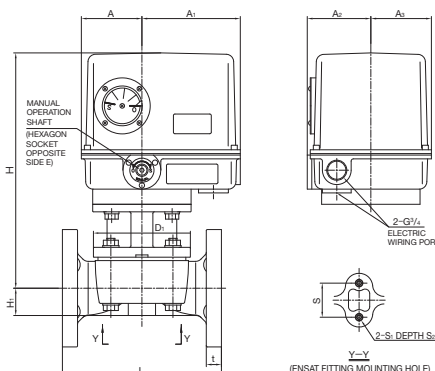

SIZE	ACTUATOR TYPE
15mm (1/2inch)	ED-11H
20mm (3/4inch)	
25mm (1inch)	
32mm (1 1/4inch)	
40mm (1 1/2inch)	
50mm (2inch)	

For detailed specifications, see **P.125**

■ JIS, DIN (Unit: mm)

mm	D1	H	H1	A	A1	A2	A3	S	S1	S2	E	JIS10K		DIN PN10	
												L	t	L	t
15	54×66	284	19.5	80	130	84	80	25	M5	10	5	110	12	130	12
20	54×66	286	17.5	80	130	84	80	25	M5	10	5	120	13	150	13
25	67×80	291	18.5	80	130	84	80	25	M5	10	5	130	13	160	13
32	67×80	294.5	22.5	80	130	84	80	25	M5	10	5	142	16	180	16
40	110×110	302.2	27.5	80	130	84	80	45	M6	14	5	180	16	200	20
50	128×128	311.2	36	80	130	84	80	45	M6	14	5	210	20	230	22

■ ANSI (Unit: inch)

inch	mm	D1	H	H1	A	A1	A2	A3	S	S1	S2	E	ANSI CLASS150			
													L	AV	t	
1/2	15	2.13×2.60	11.18	0.77	3.15	5.12	3.31	3.15	0.98	M5	0.39	0.20	GRINNELL STANDARD	4.25	4.33	0.43
3/4	20	2.13×2.60	11.26	0.69	3.15	5.12	3.31	3.15	0.98	M5	0.39	0.20	AV STANDARD	5.88	4.72	0.51
1	25	2.64×3.15	11.46	0.73	3.15	5.12	3.31	3.15	0.98	M5	0.39	0.20	GRINNELL STANDARD	5.88	5.12	0.59
1 1/4	32	2.64×3.15	11.59	0.89	3.15	5.12	3.31	3.15	0.98	M5	0.39	0.20	AV STANDARD	6.38	-	0.63
1 1/2	40	4.25×4.25	11.90	1.08	3.15	5.12	3.31	3.15	1.77	M5	0.55	0.20	GRINNELL STANDARD	6.94	7.09	0.63
2	50	4.84×4.84	12.25	1.42	3.15	5.12	3.31	3.15	1.77	M5	0.55	0.20	AV STANDARD	7.94	8.27	0.79

AUTOMATIC **ELECTRIC** **TYPE H** Single-Phase 100V
Single-Phase 200V

DIAPHRAGM VALVE TYPE 14

TYPE—A14H
CONNECTION / FLANGED—JIS, DIN, ANSI

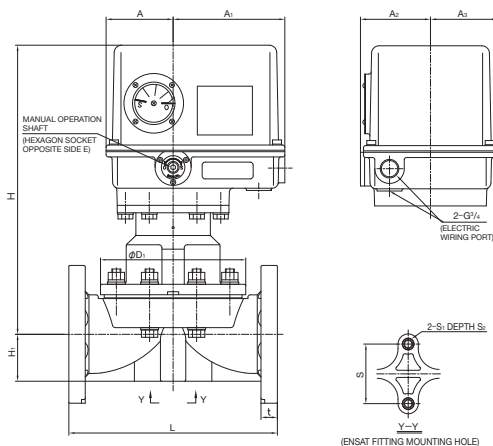

SIZE	ACTUATOR TYPE
65mm (2 1/2inch)	ED-21H
80mm (3inch)	
100mm (4inch)	

For detailed specifications, see **P.125**

■ JIS, DIN (Unit: mm)

mm	D1	H	H1	A	A1	A2	A3	S	S1	S2	E	JIS10K			DIN PN10		
												L	U-PVC C-PVC	PP PVDF	L	U-PVC C-PVC	PP PVDF
65	175	371	61	90	150	94	90	85	M8	15	5	250	22	23	290	22	22
80	199	388	63	90	150	94	90	100	M12	22	5	280	22	23	310	24	24
100	239	418	78	90	150	94	90	120	M12	22	5	340	22	24	350	24	26

■ ANSI (Unit: inch)

inch	mm	D1	H	H1	A	A1	A2	A3	S	S1	S2	E	ANSI CLASS150				
													L	AV STANDARD	U-PVC C-PVC	PP PVDF	
2 1/2	65	6.89	14.61	2.40	3.54	5.91	3.70	3.54	3.35	M8	0.59	0.20	GRINNELL STANDARD	-	9.84	0.87	0.91
3	80	7.83	15.28	2.48	3.54	5.91	3.70	3.54	3.94	M12	0.87	0.20	AV STANDARD	10.37	11.02	0.87	0.91
4	100	9.41	16.46	3.07	3.54	5.91	3.70	3.54	4.72	M12	0.87	0.20	GRINNELL STANDARD	12.93	13.39	0.87	0.94

AUTOMATIC

ELECTRIC

TYPE M

Single-Phase 100V
Single-Phase 200V

DIAPHRAGM VALVE TYPE 14

TYPE—A14M

CONNECTION / FLANGED—JIS, DIN, ANSI

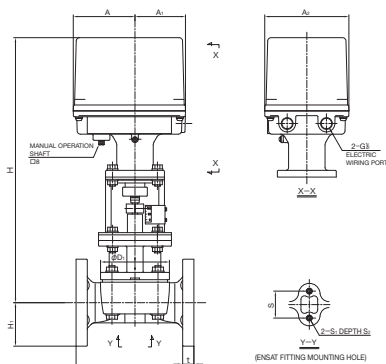

ACTUATOR SELECTION CHART

SIZE	ACTUATOR TYPE
15mm (1/2inch)	PSN1
20mm (3/4inch)	
25mm (1inch)	
32mm (1 1/4inch)	
40mm (1 1/2inch)	PSN3
50mm (2inch)	

For detailed specifications, see **P.127**

■ JIS, DIN (Unit: mm)

mm	D ₁	H	H ₁	A	A ₁	A ₂	S	S ₁	S ₂	JIS10K		DIN PN10	
										L	t	L	t
15	54×66	406	19.5	101	81	140	25	M5	10	110	12	130	12
20	54×66	408	17.5	101	81	140	25	M5	10	120	13	150	13
25	67×80	413	18.5	101	81	140	25	M5	10	130	13	160	13
32	67×80	416	22.5	101	81	140	25	M5	10	142	16	180	16
40	110×110	464	27.5	110	90	150	45	M6	14	180	16	200	20
50	123×123	473	36	110	90	150	45	M6	14	210	20	230	22

■ ANSI (Unit: inch)

inch	mm	D ₁	H	H ₁	A	A ₁	A ₂	S	S ₁	S ₂	ANSI CLASS150			
											L		t	
											GRINNELL STANDARD	AV STANDARD	U-PVC C-PVC	PP PVDF
1/2	15	2.13×2.60	15.98	0.77	3.98	3.19	5.51	0.98	M5	0.39	4.25	4.33	0.43	0.43
3/4	20	2.13×2.60	16.06	0.69	3.98	3.19	5.51	0.98	M5	0.39	5.88	4.72	0.51	0.51
1	25	2.64×3.15	16.26	0.73	3.98	3.19	5.51	0.98	M5	0.39	5.88	5.12	0.59	0.59
1 1/4	32	2.64×3.15	16.38	0.89	3.98	3.19	5.51	0.98	M5	0.39	6.38	-	0.63	0.63
1 1/2	40	4.25×4.25	18.27	1.08	4.33	3.54	5.91	1.77	M6	0.55	6.94	7.09	0.63	0.63
2	50	4.84×4.84	18.62	1.42	4.33	3.54	5.91	1.77	M6	0.55	7.94	8.27	0.79	0.79

AUTOMATIC

ELECTRIC

TYPE M

Single-Phase 100V
Single-Phase 200V

DIAPHRAGM VALVE TYPE 14

TYPE—A14M

CONNECTION / FLANGED—JIS, DIN, ANSI

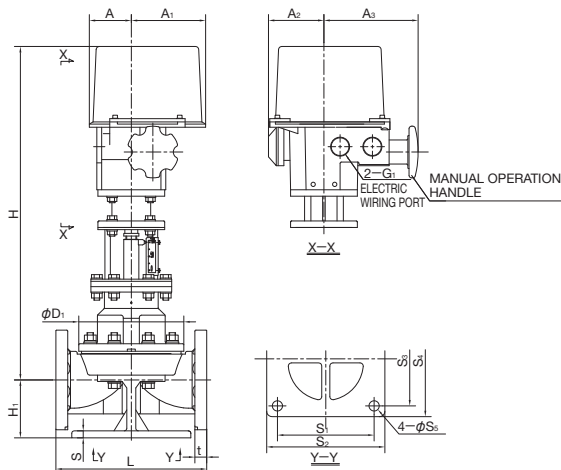

ACTUATOR SELECTION CHART

SIZE	ACTUATOR TYPE
65mm (2 1/2inch)	CSP471
80mm (3inch)	CSP771
100mm (4inch)	

For detailed specifications, see **P.127**

■ JIS, DIN (Unit: mm)

mm	D ₁	H	H ₁	A	A ₁	A ₂	A ₃	S	S ₁	S ₂	S ₃	S ₄	S ₅	JIS10K			DIN PN10		
														L	U-PVC C-PVC	PP PVDF	L	U-PVC C-PVC	PP PVDF
65	175	608	98	79	137	103	177	12	155	190	160	190	19	250	22	23	290	22	22
80	199	625	109	79	137	103	177	12	180	220	175	215	19	280	22	23	310	24	24
100	239	655	119	79	137	103	177	15	230	270	220	260	19	340	22	24	350	24	26

■ ANSI (Unit: inch)

inch	mm	D ₁	H	H ₁	A	A ₁	A ₂	A ₃	S	S ₁	S ₂	S ₃	S ₄	S ₅	ANSI CLASS150			
															L		t	
															GRINNELL STANDARD	AV STANDARD	U-PVC C-PVC	PP PVDF
2 1/2	65	6.89	23.94	3.86	3.11	5.39	4.06	6.97	0.47	6.10	7.48	6.30	7.48	0.75	-	9.84	0.87	0.91
3	80	7.83	24.61	4.29	3.11	5.39	4.06	6.97	0.47	7.09	8.66	6.89	8.46	0.75	10.37	11.02	0.87	0.91
4	100	9.41	25.79	4.69	3.11	5.39	4.06	6.97	0.59	9.06	10.63	8.66	10.24	0.75	12.93	13.39	0.87	0.94

TRUE UNION DIAPHRAGM VALVE TYPE 14

- NEAR-LINEAR FLOW CHARACTERISTICS
- NEWLY EQUIPPED WITH BOTTOM STAND WITH INSERT HOLE TO ENSURE EASY AND SECURE INSTALLATION.
- THE VALVE BODY CAN BE REMOVED FROM THE LINE.

BASIC SPECIFICATIONS

VALVE TYPE — TRUE UNION DIAPHRAGM VALVE TYPE 14

SIZE — 15 mm–50 mm (1/2 inch–2 inch)

BODY MATERIAL — U-PVC C-PVC PP PVDF

SEAL MATERIAL / DIAPHRAGM — EPDM PTFE

O-RING — EPDM FKM

CONNECTION / SOCKET — JIS, DIN, ANSI, BS
* For BS, contact us.

THREADED — Rc, Rp, NPT

	FLUID TEMPERATURE	MAXIMUM WORKING PRESSURE (NORMAL TEMPERATURE) MPa(kgf/cm ²)	CONNECTION METHOD	
			SOCKET	THREADED
U-PVC	0°C ~ 50°C	1.0 {10.2}	○	○
C-PVC	0°C ~ 90°C	1.0 {10.2}	○	○
PP	-20°C ~ 80°C	1.0 {10.2}	○	○
PVDF	-20°C ~ 100°C	1.0 {10.2}	○	○

NOTE The maximum working pressure is the value including the water hammer pressure. Be careful that the maximum working pressure is not exceeded during use.
* Concerning the allowable pressure for each temperature, material and actuator type, see the technical documents at the end of this catalog.
* The diaphragm may become loose due to temperature changes during long storage, operation stop or while in use. Check the conditions and then retighten the bolts and nuts between the bonnet and the body to the "bonnet tightening torque". (Failure to do so may cause fluid leakage.)

MANUAL



AUTOMATIC



PARTS LIST

MANUAL

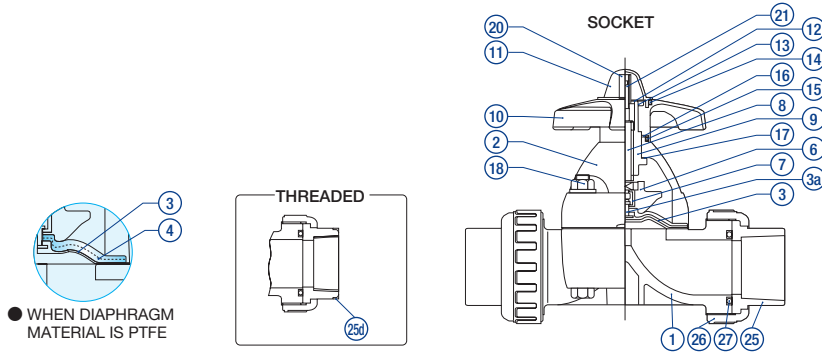

PART NO. / NAME	QTY	MATERIAL	PART NO. / NAME	QTY	MATERIAL	PART NO. / NAME	QTY	MATERIAL
① BODY	1	BODY END CONNECTOR — BONNET UNION NUT	④ CUSHION ⁽²⁾	1	EPDM	⑭ O-RING (A)	1	EPDM
② BONNET	1	U-PVC — U-PVC C-PVC — PP PP — PP PVDF — PPG ⁽¹⁾ PVDF — PVDF	⑥ COMPRESSOR	1	PVDF	⑮ O-RING (B)	1	EPDM
②⑤ END CONNECTOR	2		⑦ JOINT FITTING	1	SUS304	⑯ THRUST RING (A)	1	UHMWPE
②⑥ UNION NUT	2		⑧ STEM	1	C3604	⑰ THRUST RING (B)	1	UHMWPE
③ DIAPHRAGM	1	EPDM, PTFE, etc.	⑨ SLEEVE	1	C3604	⑱ BOLT/NUT (A)	4	SUS304
③⑩ EMBEDDED DIAPHRAGM FITTING	1	SUS304	⑩ HANDLE	1	PP	⑳ STOPPER	1	C3604
			⑪ GAUGE COVER	1	PC	㉑ SCREW	1	SUS304
			⑫ NAMEPLATE	1	U-PVC	㉒ RING ⁽³⁾	2	SUS304
			⑬ C-SHAPED STOP RING	1	SUS304	㉓ O-RING (C)	2	EPDM, etc.

NOTE (1) Bonnet PPG 15 – 100 mm: black. 125 – 250 mm: ivory. (2) is used when the diaphragm material is PTFE.
(3) is used when the threaded end connector is made of C-PVC and the size is 15 to 25 mm.

COMPATIBLE ACTUATOR

AUTOMATIC

PNEUMATIC TYPE AN For detailed specifications, see P.117

ELECTRIC TYPE H For detailed specifications, see P.125

ELECTRIC TYPE M For detailed specifications, see P.127

PRODUCT MODEL CODE LIST

MANUAL

ACTUATION	TYPE	OPERATING SYSTEM	BODY MATERIAL	SEAL MATERIAL	CONNECTION	STANDARD	SIZE			
V	T1	MH	*	*	*	*	***			
⋮	⋮	⋮	⋮	⋮	⋮	⋮	⋮			
V	MANUAL VALVE	T1	TRUE UNION	MH	ROUND HANDLE	U U-PVC C C-PVC P PP F PVDF G PVDF+PPG	E EPDM 1 PTFE+EPDM 2 PTFE+FKM	S SOCKET N THREADED P SPIGOT	J JIS D DIN A ANSI	015 15mm } 050 50mm

PRODUCT MODEL CODE LIST

AUTOMATIC

ACTUATION	TYPE	ACTUATOR TYPE	ACTION / POWER SOURCE	BODY MATERIAL	SEAL MATERIAL	CONNECTION	STANDARD	SIZE		
A	T1	*	*	*	*	*	*	***		
⋮	⋮	⋮	⋮	⋮	⋮	⋮	⋮	⋮		
A	AUTOMATIC VALVE	T1	TRUE UNION	PNEUMATIC N TYPE AN ELECTRIC H TYPE H M TYPE M	PNEUMATIC F DOUBLE ACTING G AIR TO OPEN S AIR TO CLOSE ELECTRIC 1 Single-Phase 100V 2 Single-Phase 200V D DC24V	U U-PVC C C-PVC P PP F PVDF	E EPDM 1 PTFE+EPDM 2 PTFE+FKM	S SOCKET N THREADED P SPIGOT	J JIS D DIN A ANSI	015 15mm } 050 50mm

NOTE (1) PP and PVDF sockets are weld type. Note, however, that JIS PP 32-mm socket type is not produced. (2) U-PVC and U-PVC sockets are of JIS type only. PVDF sockets are of DIN type only.

MANUAL

TRUE UNION DIAPHRAGM VALVE TYPE 14

TYPE—VT1MH

CONNECTION / SOCKET—JIS, DIN, ANSI THREADED—Rc, Rp, NPT

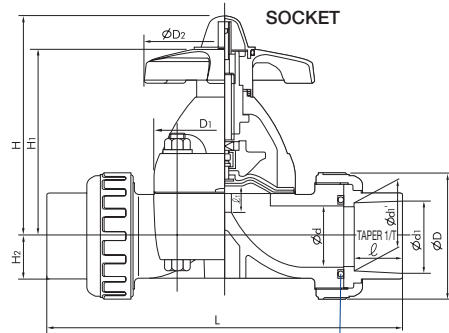
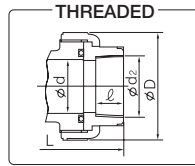
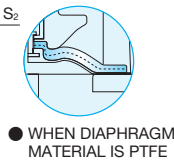
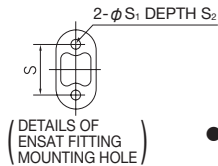

■ JIS, DIN (Unit: mm)

mm	d	D	D ₁	D ₂	ℓ ₁	H	H ₁	H ₂	S	S ₁	S ₂	JIS											
												SOCKET					THREADED						
												d ₁	ℓ	1/T	L	d ₁	d ₁ '	ℓ	L	d ₂	ℓ	U-PVC C-PVC	PP PVDF
15	16	48	54×66	100	10	104	86	19.5	25	7	13	22.11	20	1/34	134	21.2	20.2	20	134	Rc1/2	15	128	128
20	20	60	54×66	100	10	106	88	17.5	25	7	13	26.13	24	1/34	156	26.2	25.2	23	154	Rc3/4	17	148	148
25	25	70	67×80	100	12	111	93	18.5	25	7	13	32.16	27	1/34	186	33.0	32.0	25	182	Rc1	20	172	172
32	32	82	67×80	100	12	116	97	22.5	25	7	13	38.19	30	1/34	200	-	-	-	-	Rc1 1/4	22	188	188
40	40	100	108×108	156	21	177	144	27.5	45	9	15	48.21	37	1/37	271	47.0	46.0	28	253	Rc1 1/2	25	245	245
50	52	106	123×123	156	25	191	158	36	45	9	15	60.25	42	1/37	303	59.0	58.0	28	275	Rc2	28	281	278

mm	DIN										SPIGOT								
	SOCKET					THREADED					U-PVC C-PVC				PP PVDF				
	d ₁	ℓ	L	d ₁	d ₁ '	ℓ	L	d ₁	ℓ	U-PVC C-PVC	PP PVDF	U-PVC C-PVC	PP PVDF	U-PVC C-PVC	PP PVDF	PP	PVDF		
15	20	16	128	19.5	19.3	14.5	125	Rc1/2	15	128	128	20	18.5	150	20	18.5	150	2.5	1.9
20	25	19	147	24.5	24.3	16	141	Rc3/4	17	148	148	25	24	172	25	22	172	2.7	1.9
25	32	22	172	31.5	31.3	18	164	Rc1	20	172	172	32	24.5	195	32	22.5	195	3.0	2.4
32	40	26	188	39.45	39.2	20.5	177	Rc1 1/4	22	188	188	40	28	212	40	26	212	3.7	2.4
40	50	31	246	49.45	49.2	23.5	231	Rc1 1/2	25	245	245	50	34	276	50	32	276	4.6	3.0
50	63	38	294	62.5	62.1	27.5	274	Rc2	28	281	278	63	38.5	308	63	36.0	307	5.8	3.0

■ ANSI (Unit: inch)

inch	mm	d	D	D ₁	D ₂	C	H	H ₁	H ₂	S	S ₁	S ₂	ANSI										
													SOCKET					THREADED					
													ASTM SCH80			ℓ	L	ANS/ASME B1 20 1			ℓ	L	U-PVC C-PVC
1/2	15	0.63	1.89	2.13×2.60	3.94	0.39	4.09	3.39	0.77	0.98	0.28	0.51	0.848	0.836	0.875	5.47	0.83	0.87	5.43	1/2-14NPT	0.59	5.04	5.04
3/4	20	0.79	2.36	2.13×2.60	3.94	0.39	4.17	3.46	0.69	0.98	0.28	0.51	1.058	1.046	1.000	6.18	1.03	1.00	6.09	3/4-14NPT	0.67	5.83	5.83
1	25	0.98	2.76	2.64×3.15	3.94	0.47	4.37	3.66	0.79	0.98	0.28	0.51	1.325	1.310	1.125	7.32	1.30	1.13	7.24	1-11 1/2NPT	0.79	6.77	6.77
1 1/4	32	1.26	3.23	2.64×3.15	3.94	0.47	4.57	3.82	0.89	0.98	0.28	0.51	1.670	1.655	1.250	7.95	1.65	1.25	7.80	1 1/4-11 1/2NPT	0.87	7.40	7.40
1 1/2	40	1.57	3.94	4.25×4.25	6.14	0.83	6.97	5.67	1.08	1.77	0.35	0.59	1.912	1.894	1.375	10.47	1.89	1.37	10.28	1 1/2-11 1/2NPT	0.98	9.65	9.65
2	50	2.05	4.17	4.84×4.84	6.14	0.98	7.52	6.22	1.42	1.77	0.35	0.59	2.387	2.369	1.500	11.54	2.36	1.50	11.54	2-11 1/2NPT	1.10	11.06	10.95

AUTOMATIC	PNEUMATIC	TYPE AN	DOUBLE ACTING
			AIR TO OPEN
			AIR TO CLOSE

TRUE UNION DIAPHRAGM VALVE TYPE 14

TYPE—AT1N
 CONNECTION / SOCKET, THREADED—JIS, DIN, ANSI

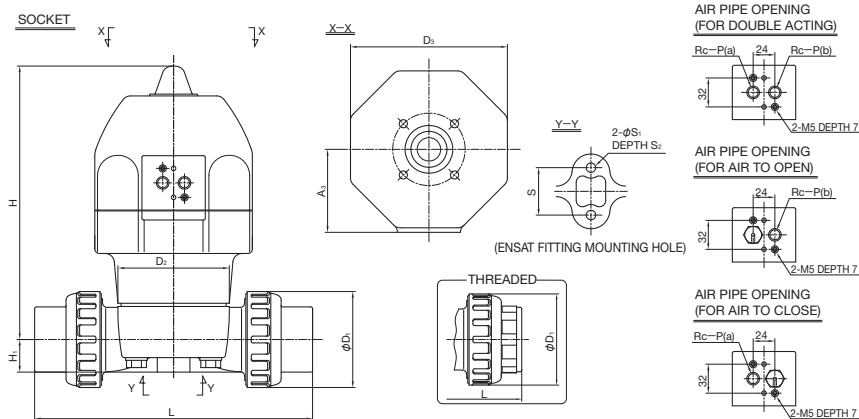

ACTUATOR SELECTION CHART

SIZE	ACTUATOR TYPE		
	DOUBLE ACTING	AIR TO OPEN	AIR TO CLOSE
15mm (1/2inch)	AN-1DA	AN-1AO	AN-1AS
20mm (3/4inch)			
25mm (1inch)	AN-2DA	AN-2AO	AN-2AS
32mm (1 1/4inch)			
40mm (1 1/2inch)	AN-3DA	AN-3AO	AN-3AS
50mm (2inch)	AN-4DA	AN-4AO	AN-4AS

For detailed specifications, see **P.117**

■ JIS, DIN (Unit: mm)

mm	D1	D2	D3	H	H1	A3	S	S1	S2	P	JIS				DIN							
											SOCKET		THREADED		SOCKET		THREADED		SPIGOT			
											L	L	L	L	L	L	L	t				
15	48	54x66	130	186	19.5	68	25	7	13	1/4	134	134	128	128	128	125	128	128	150	150	2.5	1.9
20	60	54x66	130	188	17.5	68	25	7	13	1/4	156	154	148	148	147	141	148	148	172	172	2.7	1.9
25	70	67x80	130	193	18.5	68	25	7	13	1/4	186	182	172	172	172	164	172	172	195	195	3.0	2.4
32	82	67x80	130	197	22.5	68	25	7	13	1/4	200	-	188	188	188	177	188	188	212	212	3.7	2.4
40	100	108x108	174	293	27.5	92	45	9	15	1/4	271	253	245	245	246	231	245	245	276	276	4.6	3.0
50	106	123x123	174	302	36	92	45	9	15	1/4	303	275	281	278	294	274	281	278	308	307	5.8	3.0

■ ANSI (Unit: inch)

inch	mm	D1	D2	D3	H	H1	A3	S	S1	S2	P	ANSI			
												SOCKET		THREADED	
												L	L	L	L
1/2	15	1.89	2.13x2.60	5.12	7.32	0.77	2.68	0.98	0.28	0.51	1/4	5.47	5.43	5.04	5.04
3/4	20	2.36	2.13x2.60	5.12	7.40	0.69	2.68	0.98	0.28	0.51	1/4	6.18	6.09	5.83	5.83
1	25	2.76	2.64x3.15	5.12	7.60	0.73	2.68	0.98	0.28	0.51	1/4	7.32	7.24	6.77	6.77
1 1/4	32	3.23	2.64x3.15	5.12	7.76	0.89	2.68	0.98	0.28	0.51	1/4	7.95	7.80	7.40	7.40
1 1/2	40	3.94	4.25x4.25	6.85	11.54	1.08	3.62	1.77	0.35	0.59	1/4	10.47	10.28	9.65	9.65
2	50	4.17	4.84x4.84	6.85	11.89	1.42	3.62	1.77	0.35	0.59	1/4	11.54	11.54	11.06	10.95

AUTOMATIC

ELECTRIC

TYPE H

Single-Phase 100V
Single-Phase 200V

TRUE UNION DIAPHRAGM VALVE TYPE 14

TYPE—AT1H

CONNECTION / SOCKET, THREADED—JIS, DIN, ANSI

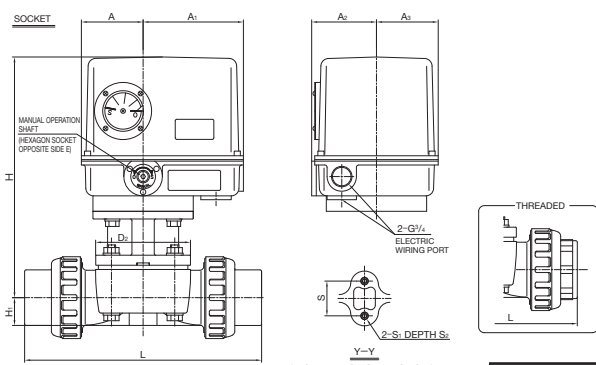

ACTUATOR SELECTION CHART

SIZE	ACTUATOR TYPE
15mm (1/2inch)	ED-11H
20mm (3/4inch)	
25mm (1inch)	
32mm (1 1/4inch)	
40mm (1 1/2inch)	
50mm (2inch)	

For detailed specifications, see P.125

■ JIS, DIN (Unit: mm)

mm	D ₂	H	H ₁	A	A ₁	A ₂	A ₃	S	S ₁	S ₂	E	JIS				DIN							
												SOCKET		THREADED		SOCKET		THREADED		SPIGOT			
												U-PVC C-PVC	PP	U-PVC C-PVC	PP PVDF	U-PVC C-PVC	PP PVDF	U-PVC C-PVC	PP PVDF	U-PVC C-PVC	PP PVDF	PP	PVDF
15	54×66	284	19.5	80	130	84	80	25	M5	10	5	134	134	128	128	128	125	128	128	150	2.5	1.9	150
20	54×66	286	17.5	80	130	84	80	25	M5	10	5	156	154	148	148	147	141	148	148	172	2.7	1.9	172
25	67×80	291	18.5	80	130	84	80	25	M5	10	5	186	182	172	172	172	164	172	172	195	3.0	2.4	195
32	67×80	294.5	22.5	80	130	84	80	25	M5	10	5	200	-	188	188	188	177	188	188	212	3.7	2.4	212
40	110×110	302.2	27.5	80	130	84	80	45	M6	14	5	271	253	245	245	246	231	245	245	276	4.6	3.0	276
50	123×123	311.2	36	80	130	84	80	45	M6	14	5	303	275	281	278	294	274	281	278	308	5.8	3.0	307

■ ANSI (Unit: inch)

inch	mm	D ₂	H	H ₁	A	A ₁	A ₂	A ₃	S	S ₁	S ₂	E	ANSI			
													SOCKET		THREADED	
													U-PVC C-PVC	PP PVDF	U-PVC C-PVC	PP PVDF
1/2	15	2.13×2.60	11.59	0.80	3.27	5.31	3.43	3.27	1.02	M5	0.41	0.20	5.47	5.43	5.04	5.04
3/4	20	2.13×2.60	11.67	0.71	3.27	5.31	3.43	3.27	1.02	M5	0.41	0.20	6.18	6.09	5.83	5.83
1	25	2.64×3.15	11.88	0.76	3.27	5.31	3.43	3.27	1.02	M5	0.41	0.20	7.32	7.24	6.77	6.77
1 1/4	32	2.64×3.15	12.02	0.92	3.27	5.31	3.43	3.27	1.02	M5	0.41	0.20	7.95	7.80	7.40	7.40
1 1/2	40	4.25×4.25	12.33	1.12	3.27	5.31	3.43	3.27	1.84	M6	0.57	0.20	10.47	10.28	9.65	9.65
2	50	4.84×4.84	12.70	1.47	3.27	5.31	3.43	3.27	1.84	M6	0.57	0.20	11.54	11.54	11.06	10.95

AUTOMATIC

ELECTRIC

TYPE M

Single-Phase 100V
Single-Phase 200V

TRUE UNION DIAPHRAGM VALVE TYPE 14

TYPE—AT1M

CONNECTION / SOCKET, THREADED—JIS, DIN, ANSI

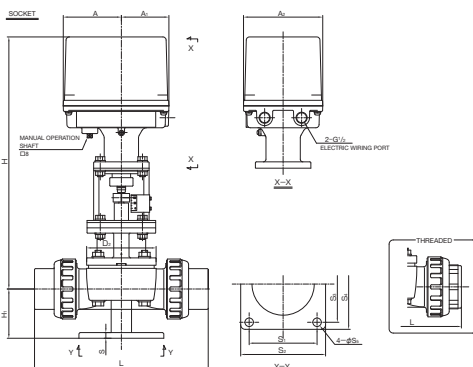

ACTUATOR SELECTION CHART

SIZE	ACTUATOR TYPE
15mm (1/2inch)	PSN1
20mm (3/4inch)	
25mm (1inch)	
32mm (1 1/4inch)	PSN3
40mm (1 1/2inch)	
50mm (2inch)	

For detailed specifications, see P.127

■ JIS, DIN (Unit: mm)

mm	D ₂	H	H ₁	A	A ₁	A ₂	S	S ₁	S ₂	S ₃	S ₄	S ₅	JIS			
													SOCKET		THREADED	
													U-PVC C-PVC	PP	U-PVC C-PVC	PP PVDF
15	54×66	406	57	101	81	140	8	50	70	60	80	12	134	134	128	128
20	54×66	408	62	101	81	140	8	60	80	65	85	12	156	154	148	148
25	67×80	413	75	101	81	140	8	65	90	70	95	15	186	182	172	172
32	67×80	416	79	101	81	140	10	90	115	110	135	15	200	-	188	188
40	110×110	464	79	110	90	150	10	90	115	110	135	15	271	253	245	245
50	123×123	473	87	110	90	150	10	120	150	135	160	15	303	275	281	278

■ ANSI (Unit: inch)

inch	mm	D ₂	H	H ₁	A	A ₁	A ₂	S	S ₁	S ₂	S ₃	S ₄	S ₅	ANSI			
														SOCKET		THREADED	
														U-PVC C-PVC	PP PVDF	U-PVC C-PVC	PP PVDF
1/2	15	2.13×2.60	15.98	2.24	3.98	3.19	5.51	0.31	1.97	2.76	2.36	3.15	0.47	5.47	5.43	5.04	5.04
3/4	20	2.13×2.60	16.06	2.44	3.98	3.19	5.51	0.31	2.36	3.15	2.56	3.35	0.47	6.18	6.09	5.83	5.83
1	25	2.64×3.15	16.26	2.95	3.98	3.19	5.51	0.31	2.56	3.54	2.76	3.74	0.59	7.32	7.24	6.77	6.77
1 1/4	32	2.64×3.15	16.38	3.11	3.98	3.19	5.51	0.39	3.54	4.53	4.33	5.31	0.59	7.95	7.80	7.40	7.40
1 1/2	40	4.25×4.25	18.27	3.11	4.33	3.54	5.91	0.39	3.54	4.53	4.33	5.31	0.59	10.47	10.28	9.65	9.65
2	50	4.84×4.84	18.62	3.43	4.33	3.54	5.91	0.39	4.72	5.91	5.31	6.30	0.59	11.54	11.54	11.06	10.95

DIAPHRAGM VALVE TYPE 15

- NEAR-LINEAR FLOW CHARACTERISTICS
- REQUIRES LESS HANDLE OPERATION FORCE THANKS TO IMPROVED MATERIAL AND SHAPE.
- THE GAUGE COVER ALSO SERVES AS AN INDICATOR, ALLOWING EASY CHECK OF OPENING DEGREE.

BASIC SPECIFICATIONS

VALVE TYPE ————— **DIAPHRAGM VALVE TYPE 15**

SIZE ————— **125 mm, 150 mm (5 inch, 6 inch)**

BODY MATERIAL ————— **U-PVC PP PVDF**

SEAL MATERIAL / DIAPHRAGM ————— **EPDM PTFE FKM etc.**

CONNECTION / FLANGED ————— **JIS10K, DIN PN10, ANSI CLASS150**

	FLUID TEMPERATURE	MAXIMUM WORKING PRESSURE (NORMAL TEMPERATURE) MPa(kgf/cm ²)				CONNECTION METHOD
		DIAPHRAGM: RUBBER		DIAPHRAGM: PTFE		
		125mm	150mm	125mm	150mm	FLANGED
U-PVC	0°C ~ 60°C	0.8 {8.2}	0.8 {8.2}	0.7 {7.1}	0.5 {5.1}	○
PP	-20°C ~ 90°C	0.8 {8.2}	0.8 {8.2}	0.7 {7.1}	0.5 {5.1}	○
PVDF	-40°C ~ 120°C	0.8 {8.2}	0.8 {8.2}	0.7 {7.1}	0.5 {5.1}	○

NOTE The maximum working pressure is the value including the water hammer pressure. Be careful that the maximum working pressure is not exceeded during use.

* Concerning the allowable pressure for each temperature, material and actuator type, see the technical documents at the end of this catalog.

* The diaphragm may become loose due to temperature changes during long storage, operation stop or while in use. Check the conditions and then retighten the bolts and nuts between the bonnet and the body to the "bonnet tightening torque". (Failure to do so may cause fluid leakage.)

MANUAL



AUTOMATIC

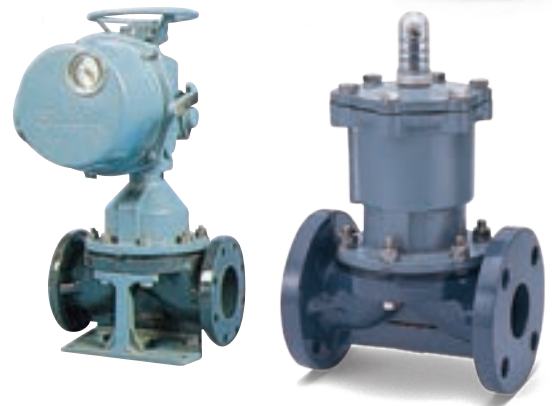

PARTS LIST **MANUAL**

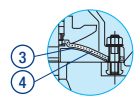

WHEN DIAPHRAGM MATERIAL IS PTFE

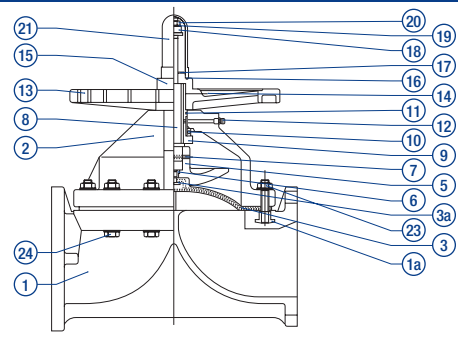

PART NO. / NAME	QTY	MATERIAL	PART NO. / NAME	QTY	MATERIAL	PART NO. / NAME	QTY	MATERIAL
① BODY	1	BODY ——— BONNET U-PVC ——— U-PVC PP ——— PP PVDF ——— PPG ⁽¹⁾ PVDF ——— PVDF	⑦ COMPRESSOR PIN	1	SUS304	⑰ VALVE SEAT	1	SUS304
② BONNET	1		⑧ STEM	1	C3604	⑱ STOPPER	1	SS400 (Unichrome plating)
③ DIAPHRAGM	1	EPDM, PTFE, etc.	⑨ SLEEVE (A)	1	C3604	⑲ SPRING WASHER	1	SUS304
③a EMBEDDED DIAPHRAGM FITTING	1	SUS304	⑩ THRUST BEARING (A)	1	SUJ2	⑳ SET NUT	1	SUS304
④ CUSHION ⁽²⁾	1	EPDM, etc.	⑪ O-RING (A)	1	NBR	㉑ GAUGE COVER	1	PC
⑤ COMPRESSOR	1	PVDF	⑫ GREASE NIPPLE	1	C3604	㉒ BOLT/NUT	4	SUS304
⑥ COMPRESSOR NUT	1	C3604	⑬ HANDLE	1	PP	㉓ BOLT/NUT	—	SUS304
			⑭ NAMEPLATE	1	U-PVC	⑰ STUD NUT	4	C3604 ⁽³⁾ , SUS304 ⁽⁴⁾
			⑮ CAP	1	PP			
			⑯ GASKET (A)	1	EPDM			

NOTE (1) Bonnet PPG 15 – 100 mm: black. 125 – 250 mm: ivory. (2) is used when the diaphragm material is PTFE. (3) is used when the body material is U-PVC or PP. (4) is used when the body material is PVDF.

HANDLE ROTATION [FULL OPEN (ROTATION/LIFT) FULL CLOSE] MANUAL			
SIZE	ROTATION	SIZE	ROTATION
125mm (5inch)	10.0	150mm (6inch)	11.0

COMPATIBLE ACTUATOR **AUTOMATIC**

PNEUMATIC	TYPE AV	For detailed specifications, see P.118	ELECTRIC	TYPE H	For detailed specifications, see P.125
			ELECTRIC	TYPE S	For detailed specifications, see P.131

PRODUCT MODEL
CODE LIST
MANUAL

ACTUATION	TYPE	OPERATING SYSTEM	BODY MATERIAL	SEAL MATERIAL	CONNECTION	STANDARD	SIZE
V	15	MH	*	*	F	*	***
⋮	⋮	⋮	⋮	⋮	⋮	⋮	⋮
V MANUAL VALVE	15 TYPE 15	MH ROUND HANDLE	U U-PVC P PP F PVDF G PVDF+PPG	E EPDM T PTFE	F FLANGED	1 JIS10K 5 5K D DIN A ANSI	125 125mm 150 150mm

PRODUCT MODEL
CODE LIST
AUTOMATIC

ACTUATION	TYPE	ACTUATOR TYPE	ACTION / POWER SOURCE	BODY MATERIAL	SEAL MATERIAL	CONNECTION	STANDARD	SIZE
A	15	*	*	*	*	F	*	***
⋮	⋮	⋮	⋮	⋮	⋮	⋮	⋮	⋮
A AUTOMATIC VALVE	15 TYPE 15	PNEUMATIC V TYPE AV ELECTRIC H TYPE H S TYPE S	PNEUMATIC F DOUBLE ACTING G AIR TO OPEN S AIR TO CLOSE ELECTRIC 1 Single-Phase 100V 2 Single-Phase 200V 3 Three-Phase AC200V 4 Three-Phase AC400V	U U-PVC P PP F PVDF	E EPDM T PTFE	F FLANGED	1 JIS10K 5 JIS5K D DIN A ANSI	125 125mm 150 150mm

MANUAL

DIAPHRAGM VALVE TYPE 15

TYPE—V15MH

CONNECTION / FLANGED—JIS, DIN, ANSI

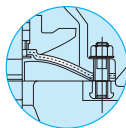

WHEN DIAPHRAGM
MATERIAL IS PTFE

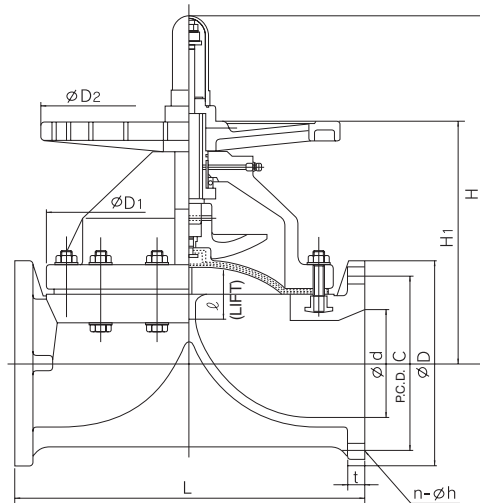

■ JIS, DIN (Unit: mm)

mm	d	D ₁	D ₂	ℓ	H	H ₁	JIS						DIN PN10											
							JIS5K			JIS10K			U-PVC		PP PVDF		DIN PN10			U-PVC		PP PVDF		
							D	C	n	h	D	C	n	h	L	t	D	C	n	h	L	t	t	
125	125	320	300	60	420	308	235	200	8	19	250	210	8	23	410	22	24	250	210	8	18	400	22	23
150	148	385	410	70	476	334	265	230	8	19	280	240	8	23	480	24	27	285	240	8	22	480	24	27

■ ANSI (Unit: inch)

inch	mm	d	D ₁	D ₂	ℓ	H	H ₁	ANSI							
								ANSI CLASS150					t		
								D	C	n	h	L	U-PVC	PP PVDF	
5	125	4.92	12.60	11.81	2.36	16.54	12.13	10.00	8.50	8	0.88	16.14	0.87	0.94	
6	150	5.83	15.16	16.14	2.76	18.74	13.15	11.00	9.50	8	0.88	18.90	0.94	1.06	

AUTOMATIC PNEUMATIC TYPE AV
DOUBLE ACTING
 AIR TO OPEN
 AIR TO CLOSE

DIAPHRAGM VALVE TYPE 15

TYPE—A15V
 CONNECTION / FLANGED—JIS, DIN, ANSI

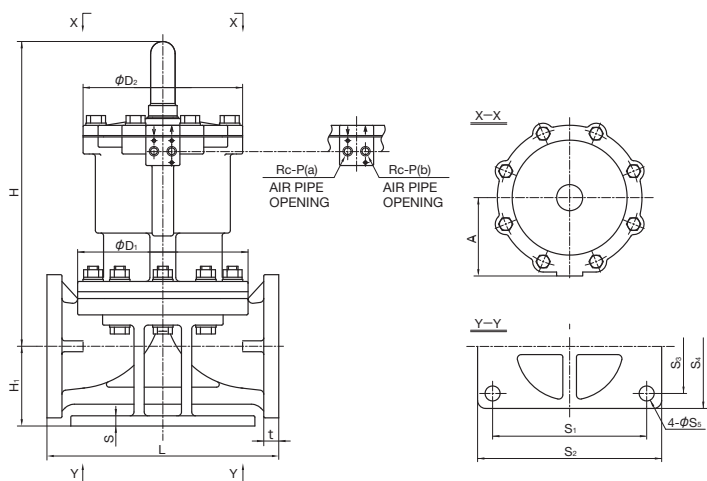

ACTUATOR SELECTION CHART

SIZE	ACTUATOR TYPE
125mm (5inch)	AV-4DA
150mm (6inch)	AV-5DA

For detailed specifications, see **P.118**

■ JIS, DIN (Unit: mm)

mm	D ₁	D ₂	A	H	H ₁	S	S ₁	S ₂	S ₃	S ₄	S ₅	P	JIS5K, JIS10K			DIN PN10				
													L	t		L	t			
125	320	305	150	508	134	15	310	350	280	320	23	1/4	410	U-PVC	PP PVDF	24	400	U-PVC	PP PVDF	23
150	385	385	195	566	145	16	360	400	310	350	23	1/4	480	24	27		480	24	27	

■ ANSI (Unit: inch)

inch	mm	D ₁	D ₂	A	H	H ₁	S	S ₁	S ₂	S ₃	S ₄	S ₅	P	ANSI CLASS150				
														L	t			
5	125	12.60	12.01	5.91	20.00	5.28	0.59	12.20	13.78	11.02	12.60	0.91	1/4	16.14	U-PVC	PP PVDF	0.87	0.94
6	150	15.16	15.16	7.68	22.28	5.71	0.63	14.17	15.75	12.20	13.78	0.91	1/4	18.90	0.94	1.06		

AUTOMATIC PNEUMATIC TYPE AV
DOUBLE ACTING
 AIR TO OPEN
 AIR TO CLOSE

DIAPHRAGM VALVE TYPE 15

TYPE—A15V
 CONNECTION / FLANGED—JIS, DIN, ANSI

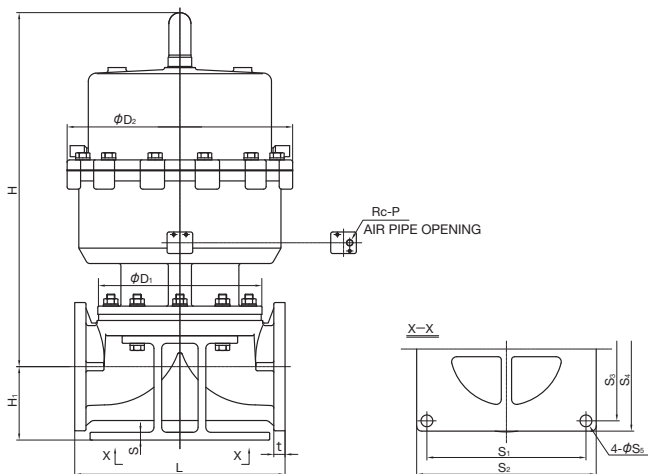

ACTUATOR SELECTION CHART

SIZE	ACTUATOR TYPE
125mm (5inch)	AV-4A0
150mm (6inch)	AV-5A0

For detailed specifications, see **P.118**

■ JIS, DIN (Unit: mm)

mm	D ₁	D ₂	H	H ₁	H ₂	S	S ₁	S ₂	S ₃	S ₄	S ₅	P	JIS5K, JIS10K			DIN PN10				
													L	t		L	t			
125	320	455	690	143	15	310	350	280	320	23	23	1/4	410	U-PVC	PP PVDF	24	400	U-PVC	PP PVDF	23
150	385	520	790	148	16	360	400	310	350	23	23	1/4	480	24	27		480	24	27	

■ ANSI (Unit: inch)

inch	mm	D ₁	D ₂	H	H ₁	H ₂	S	S ₁	S ₂	S ₃	S ₄	S ₅	P	ANSI CLASS150			
														L	t		
5	125	12.60	17.91	20.00	5.28	0.59	12.20	13.78	11.02	12.60	0.91	1/4	16.14	U-PVC	PP PVDF	0.87	0.94
6	150	15.16	20.47	22.28	5.71	0.63	14.17	15.75	12.20	13.78	0.91	1/4	18.90	0.94	1.06		

AUTOMATIC

PNEUMATIC

TYPE AV

DOUBLE ACTING

AIR TO OPEN

AIR TO CLOSE

DIAPHRAGM VALVE TYPE 15

TYPE—A15V

CONNECTION / FLANGED—JIS, DIN, ANSI

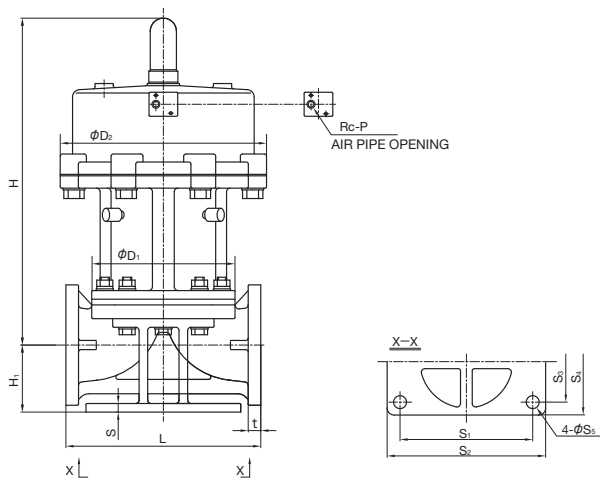

ACTUATOR SELECTION CHART

SIZE	ACTUATOR TYPE
125mm (5inch)	AV-4AS
150mm (6inch)	AV-5AS

For detailed specifications, see **P.118**

■ JIS, DIN (Unit: mm)

mm	D ₁	D ₂	H	H ₁	S	S ₁	S ₂	S ₃	S ₄	S ₅	P	JIS5K, JIS10K			DIN PN10				
												L	t		L	t			
125	320	455	653	143	15	310	350	280	320	23	1/4	410	U-PVC	PP PVDF	24	400	U-PVC	PP PVDF	23
150	385	520	722	148	16	360	400	310	350	23	1/4	480	24	27	480	24	27		

■ ANSI (Unit: inch)

inch	mm	D ₁	D ₂	H	H ₁	S	S ₁	S ₂	S ₃	S ₄	S ₅	P	ANSI CLASS150				
													L	t			
5	125	12.60	17.91	25.71	5.63	0.59	12.20	13.78	11.02	12.60	0.91	1/4	16.14	U-PVC	PP PVDF	0.87	0.94
6	150	15.16	20.47	28.43	5.83	0.63	14.17	15.75	12.20	13.78	0.91	1/4	18.90	0.94	1.06		

AUTOMATIC **ELECTRIC** **TYPE H** Single-Phase 100V
Single-Phase 200V

DIAPHRAGM VALVE TYPE 15

TYPE—A15H
CONNECTION / FLANGED—JIS, DIN, ANSI

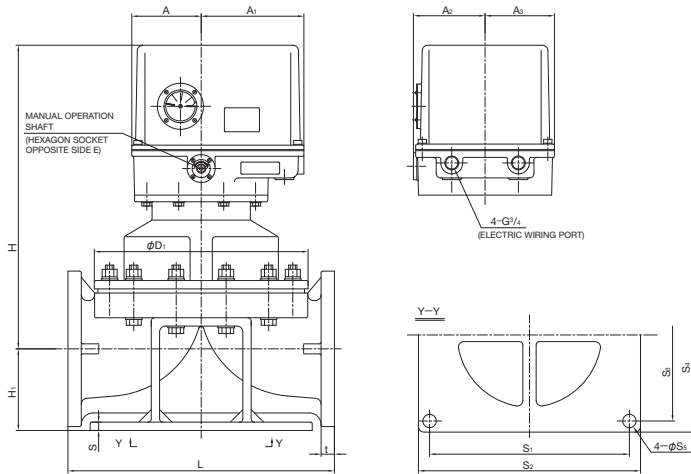

ACTUATOR SELECTION CHART

SIZE	ACTUATOR TYPE
125mm (5inch)	ED-30H
150mm (6inch)	

For detailed specifications, see **P.125**

■ JIS, DIN (Unit: mm)

mm	D ₁	H	H ₁	A	A ₁	A ₂	A ₃	S	S ₁	S ₂	S ₃	S ₄	S ₅	E	JIS5K, JIS10K			DIN PN10				
															L	t		L	t			
125	320	510	134	125	185	129	125	15	310	350	280	320	23	6	410	U-PVC	PP	PVDF	400	U-PVC	PP	PVDF
150	385	550	145	125	185	129	125	16	360	400	310	350	23	6	480	22	24	27	480	22	23	27

■ ANSI (Unit: inch)

inch	mm	D ₁	H	H ₁	A	A ₁	A ₂	A ₃	S	S ₁	S ₂	S ₃	S ₄	S ₅	E	ANSI CLASS150					
																L	t				
5	125	12.60	20.08	5.28	4.92	7.28	5.08	4.92	0.59	12.20	13.78	11.02	12.60	0.91	0.24	16.14	U-PVC	PP	PVDF	0.87	0.94
6	150	15.16	21.65	5.71	4.92	7.28	5.08	4.92	0.63	14.17	15.75	12.20	13.78	0.91	0.24	18.90	0.94	1.06			

AUTOMATIC **ELECTRIC** **TYPE S** Three-Phase AC200V
Three-Phase AC400V

DIAPHRAGM VALVE TYPE 15

TYPE—A15S
CONNECTION / FLANGED—JIS, DIN, ANSI

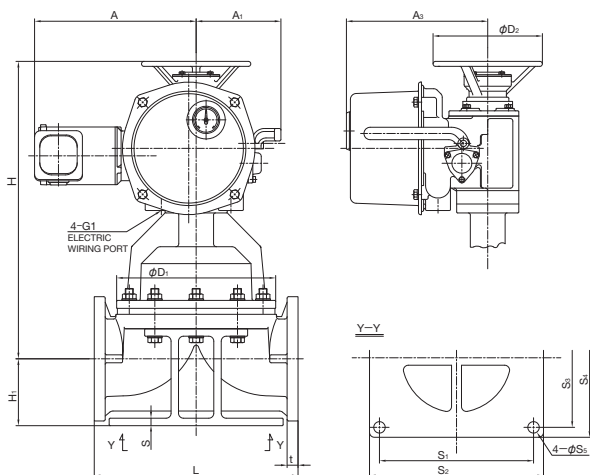

ACTUATOR SELECTION CHART

SIZE	ACTUATOR TYPE
125mm (5inch)	LTRM-01

For detailed specifications, see **P.131**

■ JIS, DIN (Unit: mm)

mm	D ₁	D ₂	H	H ₁	A	A ₁	A ₃	S	S ₁	S ₂	S ₃	S ₄	S ₅	E	JIS5K, JIS10K			DIN PN10				
															L	t		L	t			
125	320	220	590	134	325	171	284	15	310	350	280	320	23	6	410	U-PVC	PP	PVDF	400	U-PVC	PP	PVDF

■ ANSI (Unit: inch)

inch	mm	D ₁	D ₂	H	H ₁	A	A ₁	A ₃	S	S ₁	S ₂	S ₃	S ₄	S ₅	E	ANSI CLASS150					
																L	t				
5	125	12.60	8.66	23.23	5.28	12.80	6.73	11.18	0.59	12.20	13.78	11.02	12.60	0.91	0.24	16.14	U-PVC	PP	PVDF	0.87	0.94

AUTOMATIC

ELECTRIC

TYPE S

Three-Phase
AC200V
+
Three-Phase
AC400V

DIAPHRAGM VALVE TYPE 15

TYPE—A15S

CONNECTION / FLANGED—JIS, DIN, ANSI

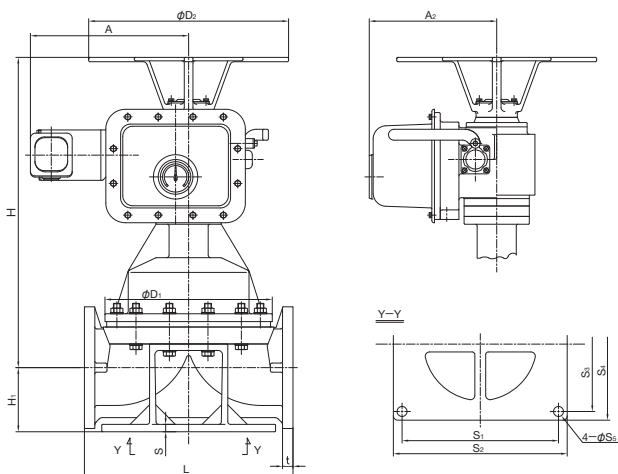

ACTUATOR SELECTION CHART

SIZE	ACTUATOR TYPE
150mm (6inch)	LTMD-01 (AUTOMATIC RETURN) MECHANISM
	LTKD-01 (MANUAL RETURN) MECHANISM

For detailed specifications, see **P.131**

■ JIS, DIN (Unit: mm)

mm	D ₁	D ₂	H	H ₁	A	A ₂	S	S ₁	S ₂	S ₃	S ₄	S ₅	JIS5K, JIS10K			DIN PN10		
													L	t	PP PVDF	L	t	PP PVDF
150	385	460	714	145	357	293	16	360	400	310	350	23	480	24	27	480	24	27

■ ANSI (Unit: inch)

inch	mm	D ₁	D ₂	H	H ₁	A	A ₂	S	S ₁	S ₂	S ₃	S ₄	S ₅	ANSI CLASS150		
														L	t	PP PVDF
6	150	15.16	18.11	28.11	5.71	14.06	11.54	0.63	14.17	15.75	12.20	13.78	0.91	18.90	0.94	1.06

DIAPHRAGM VALVE TYPE 72

- NEAR-LINEAR FLOW CHARACTERISTICS
- TRANSPARENT GAUGE COVER (MADE OF POLYCARBONATE) PROTECTS THE INTERNAL AND EXTERNAL PARTS FROM CORROSIVE CHEMICAL SOLUTIONS AND GASES.
- THE GAUGE COVER ALSO SERVES AS AN INDICATOR, ALLOWING EASY CHECK OF OPENING DEGREE.

BASIC SPECIFICATIONS

VALVE TYPE ————— DIAPHRAGM VALVE TYPE 72

SIZE ————— 200 mm, 250 mm (8 inch, 10 inch)

BODY MATERIAL ————— **U-PVC** **PP** **PVDF**

SEAL MATERIAL / DIAPHRAGM ————— **EPDM** **PTFE** **FKM** etc.

CONNECTION / FLANGED — JIS5K, JIS10K, DIN PN10, ANSI CLASS150

MODEL A (STANDARD)	FLUID TEMPERATURE	MAXIMUM WORKING PRESSURE (NORMAL TEMPERATURE) MPa(kgf/cm ²)				CONNECTION METHOD
		DIAPHRAGM: RUBBER		DIAPHRAGM: PTFE		
		200mm	250mm	200mm	250mm	FLANGED
U-PVC	0°C ~ 60°C	0.3 {3.1}	0.3 {3.1}	0.2 {2.0}	0.2 {2.0}	○
PP	-20°C ~ 90°C	0.5 {5.1}	0.45 {4.6}	0.4 {4.1}	0.4 {4.1}	○
PVDF	-40°C ~ 120°C	0.5 {5.1}	0.45 {4.6}	0.4 {4.1}	0.4 {4.1}	○

MODEL B (OPTION)	FLUID TEMPERATURE	MAXIMUM WORKING PRESSURE (NORMAL TEMPERATURE) MPa(kgf/cm ²)				CONNECTION METHOD
		DIAPHRAGM: RUBBER		DIAPHRAGM: PTFE		
		200mm	250mm	200mm	250mm	FLANGED
U-PVC	0°C ~ 60°C	0.5 {5.1}	0.45 {4.6}	0.4 {4.1}	0.4 {4.1}	○
PP	-20°C ~ 90°C	0.5 {5.1}	0.45 {4.6}	0.4 {4.1}	0.4 {4.1}	○
PVDF	-40°C ~ 120°C	—	—	0.4 {4.1}	0.4 {4.1}	○

NOTE The maximum working pressure is the value including the water hammer pressure. Be careful that the maximum working pressure is not exceeded during use.

* Concerning the allowable pressure for each temperature, material and actuator type, see the technical documents at the end of this catalog.

* The diaphragm may become loose due to temperature changes during long storage, operation stop or while in use. Check the conditions and then retighten the bolts and nuts between the bonnet and the body to the "bonnet tightening torque". (Failure to do so may cause fluid leakage.)

MANUAL



AUTOMATIC

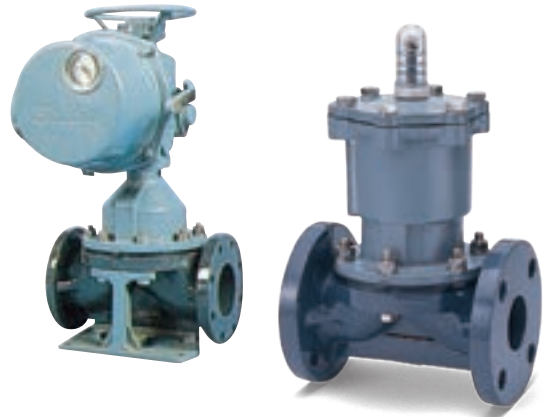

PARTS LIST **MANUAL**

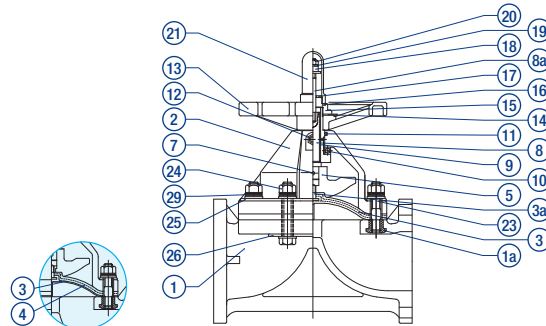

WHEN DIAPHRAGM MATERIAL IS PTFE

PART NO. / NAME	QTY	MATERIAL	PART NO. / NAME	QTY	MATERIAL	PART NO. / NAME	QTY	MATERIAL
① BODY	1	BODY — BONNET U-PVC — U-PVC PP — PP PVDF — PPG (1) PVDF — PVDF	⑨ SLEEVE (A)	1	C3604	⑲ SPRING WASHER	1	SUS304
② BONNET	1		⑩ THRUST BEARING (A)	1	SUJ2	⑳ SET NUT	1	SUS304
③ DIAPHRAGM	1	EPDM, PTFE, etc.	⑪ O-RING (A)	1	NBR	㉑ GAUGE COVER	1	PC
④ CUSHION (2)	1	EPDM, etc.	⑫ GREASE NIPPLE	1	C3604	㉒ BOLT/NUT	—	SUS304
⑤ COMPRESSOR	1	FC200 (Unichrome plating)	⑬ HANDLE	1	PP	㉓ BOLT/NUT	—	SUS304
⑦ COMPRESSOR PIN	1	SUS304	⑭ NAMEPLATE	1	U-PVC	㉔ BONNET TOP LINER (3)	1 SET	SUS304
⑧ STEM	1	C3604	⑮ CAP	1	PP	㉕ BODY LINER (3)	1 SET	SUS304
8a DISPLAY LOT	1	SUS304	⑯ GASKET (A)	1	EPDM	㉖ DISC SPRING WASHER (4)	—	SUS304
			⑰ VALVE SEAT	1	SUS304	⑳ STUD NUT	—	SUS304
			⑱ STOPPER	1	SS400 (Unichrome plating)	3a EMBEDDED DIAPHRAGM FITTING (A)	1	SUS304, TITANIUM (with palladium)

NOTE (1) Bonnet PPG 15 – 100 mm: black. 125 – 250 mm: ivory. (2) is used when the diaphragm material is PTFE. (3) is used when the body material is PP or PVDF. (4) is used when the body material is PVDF. (5) The dimensional drawing and part drawing show a product that uses PVDF as the body material.

HANDLE ROTATION [FULL OPEN (ROTATION/LIFT) FULL CLOSE] **MANUAL**

SIZE	ROTATION	SIZE	ROTATION
200mm (8inch)	19	250mm (10inch)	25

COMPATIBLE ACTUATOR **AUTOMATIC**

PNEUMATIC TYPE AV For detailed specifications, see P.118

ELECTRIC TYPE S For detailed specifications, see P.131

PRODUCT MODEL
CODE LIST
MANUAL

ACTUATION	TYPE	OPERATING SYSTEM	BODY MATERIAL	SEAL MATERIAL	CONNECTION	STANDARD	SIZE
V	72	MH	*	*	F	*	***
⋮	⋮	⋮	⋮	⋮	⋮	⋮	⋮
V MANUAL VALVE	72 TYPE 72	MH ROUND HANDLE	U U-PVC P PP F PVDF G PVDF+PPG	E EPDM T PTFE	F FLANGED	1 JIS10K 5 5K D DIN A ANSI	200 200mm • 250 250mm

PRODUCT MODEL
CODE LIST
AUTOMATIC

ACTUATION	TYPE	ACTUATOR TYPE	ACTION / POWER SOURCE	BODY MATERIAL	SEAL MATERIAL	CONNECTION	STANDARD	SIZE
A	72	*	*	*	*	F	*	***
⋮	⋮	⋮	⋮	⋮	⋮	⋮	⋮	⋮
A AUTOMATIC VALVE	72 TYPE 72	PNEUMATIC V TYPE AV ELECTRIC S TYPE S	PNEUMATIC F DOUBLE ACTING ELECTRIC 3 Three-Phase AC200V 4 Three-Phase AC400V	U U-PVC P PP F PVDF	E EPDM T PTFE	F FLANGED	1 JIS10K 5 JIS5K D DIN A ANSI	200 200mm • 250 250mm

MANUAL

DIAPHRAGM VALVE TYPE 72

TYPE—V72MH

CONNECTION / FLANGED—JIS, DIN, ANSI

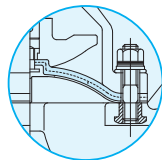

WHEN DIAPHRAGM MATERIAL IS PTFE

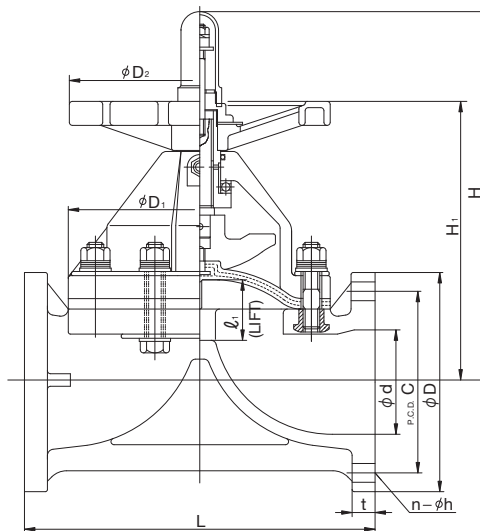

■ JIS, DIN (Unit: mm)

mm	d	D ₁	D ₂	ℓ	H ₁	H	JIS								DIN PN10									
							JIS5K				JIS10K				t		D	C	n	h	L	t		
							D	C	n	h	D	C	n	h	L	U-PVC						PP PVDF	D	C
200	196	430	410	95	419	627	320	280	8	23	330	290	12	23	570	28	32	295	340	8	22	600	30	34
250	247	540	560	128	510	778	385	345	12	23	400	355	12	25	680	30	37	350	395	12	22	730	34	36

■ ANSI (Unit: inch)

inch	mm	d	D ₁	D ₂	ℓ	H ₁	H	ANSI					
								D	C	n	h	L	t
8	200	7.72	16.93	16.14	3.74	16.50	24.69	13.50	11.75	8	0.88	22.44	1.26
10	250	9.72	21.26	22.05	5.04	20.08	30.63	16.00	14.25	12	1.00	26.77	1.46

AUTOMATIC PNEUMATIC TYPE AV
DOUBLE ACTING
 AIR TO OPEN
 AIR TO CLOSE

DIAPHRAGM VALVE TYPE 72

TYPE—A72V
 CONNECTION / FLANGED—JIS, DIN, ANSI

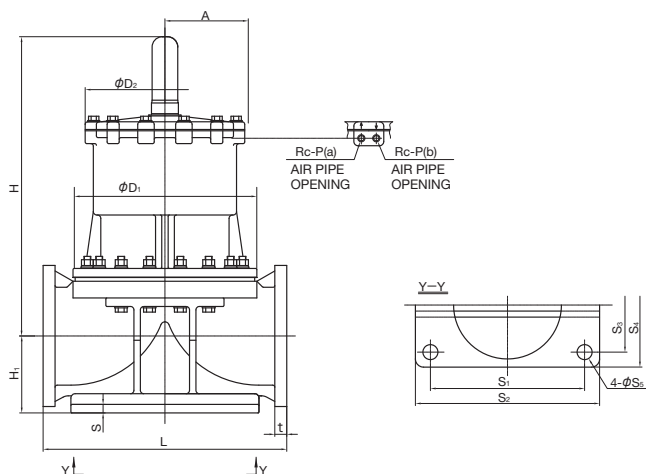

ACTUATOR SELECTION CHART

SIZE	ACTUATOR TYPE
200mm (8inch)	AV-6DA
250mm (10inch)	AV-7DA

For detailed specifications, see **P.118**

■ JIS, DIN (Unit: mm)

mm	D ₁	D ₂	A	H	H ₁	S	S ₁	S ₂	S ₃	S ₄	S ₅	P	JIS5K, JIS10K			DIN PN10		
													L	U-PVC	PP PVDF	L	U-PVC	PP PVDF
200	430	385	195	742	179	20	390	440	330	380	23	3/8	570	28	32	600	30	34
250	540	520	260	890	215	23	470	540	390	460	25	3/8	680	30	37	730	34	36

■ ANSI (Unit: inch)

inch	mm	D ₁	D ₂	A	H	H ₁	S	S ₁	S ₂	S ₃	S ₄	S ₅	P	ANSI CLASS150		
														L	t	t
8	200	16.93	15.16	7.68	29.21	7.05	0.79	15.35	17.32	12.99	14.96	0.91	3/8	22.44	1.26	
10	250	21.26	20.47	10.24	35.04	8.46	0.91	18.50	21.26	15.35	18.11	0.98	3/8	26.77	1.46	

AUTOMATIC ELECTRIC TYPE S
 Three-Phase AC200V
 Three-Phase AC400V

DIAPHRAGM VALVE TYPE 72

TYPE—A72S
 CONNECTION / FLANGED—JIS, DIN, ANSI

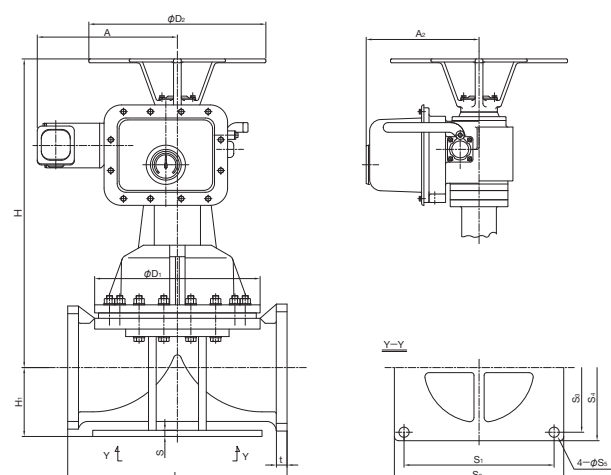

ACTUATOR SELECTION CHART

SIZE	ACTUATOR TYPE
200mm (8inch)	LTMD-01 (AUTOMATIC RETURN MECHANISM)
	LTKD-01 (MANUAL RETURN MECHANISM)
250mm (10inch)	LTMD-02 (AUTOMATIC RETURN MECHANISM)
	LTKD-02 (MANUAL RETURN MECHANISM)

For detailed specifications, see **P.131**

■ JIS, DIN (Unit: mm)

mm	D ₁	D ₂	H	H ₁	A	A ₂	S	S ₁	S ₂	S ₃	S ₄	JIS5K, JIS10K			DIN PN10		
												L	U-PVC	PP PVDF	L	U-PVC	PP PVDF
200	430	460	802	179	357	293	20	390	440	330	380	570	28	32	600	30	34
250	540	460	989	215	375	328	23	470	540	390	460	680	30	37	730	34	36

■ ANSI (Unit: inch)

inch	mm	D ₁	D ₂	H	H ₁	A	A ₂	S	S ₁	S ₂	S ₃	S ₄	ANSI CLASS150		
													L	t	t
8	200	16.93	18.11	31.57	7.05	14.06	11.54	0.79	15.35	17.32	12.99	14.96	22.44	1.26	
10	250	21.26	18.11	38.94	8.46	14.76	12.91	0.91	18.50	21.26	15.35	18.11	26.77	1.46	

ASAHI AV

DIAPHRAGM VALVE TYPE AI / TRUE UNION DIAPHRAGM VALVE TYPE AI

- NEAR-LINEAR FLOW CHARACTERISTICS
- MAXIMUM WORKING PRESSURE OF 1.0 MPa. EXCELLENT OPEN/CLOSE DURABILITY TO WITHSTAND MORE THAN 500,000 CYCLES OF OPENING AND CLOSING.
- FOR THE AIR TO OPEN TYPE, TWO SPEC TYPES (1.0 MPa AND 0.7 MPa) ARE AVAILABLE.
- ALL-PLASTIC DESIGN ENSURES EXCELLENT CORROSION RESISTANCE.

DIAPHRAGM VALVE (TYPE AI) BASIC SPECIFICATIONS

VALVE TYPE — DIAPHRAGM VALVE (TYPE AI)
 SIZE — 15 mm—50 mm (1/2 inch—2 inch)
 BODY MATERIAL — U-PVC C-PVC PP PVDF
 SEAL MATERIAL / DIAPHRAGM — EPDM PTFE FKM etc.
 CONNECTION / FLANGED — JIS10K, DIN PN10, ANSI CLASS150

TRUE UNION DIAPHRAGM VALVE (TYPE AI) BASIC SPECIFICATIONS

VALVE TYPE — TRUE UNION DIAPHRAGM VALVE (TYPE AI)
 SIZE — 15 mm—50 mm (1/2 inch—2 inch)
 BODY MATERIAL — U-PVC C-PVC PP PVDF
 SEAL MATERIAL / DIAPHRAGM — EPDM PTFE
 O-RING — EPDM FKM
 CONNECTION / SOCKET — JIS, DIN, ANSI
 THREADED — Rc, Rp, NPT

	FLUID TEMPERATURE	MAXIMUM WORKING PRESSURE (NORMAL TEMPERATURE) (MPa)(kg/cm ²)	CONNECTION METHOD		
			FLANGED	SOCKET	THREADED
U-PVC	0°C ~ 60°C	1.0 {10.2}	○	○	○
C-PVC	0°C ~ 90°C	1.0 {10.2}	○	○	○
PP	-20°C ~ 90°C	1.0 {10.2}	○	○	○
PVDF	-20°C ~ 120°C	1.0 {10.2}	○	○	○

NOTE The maximum working pressure is the value including the water hammer pressure. Be careful that the maximum working pressure is not exceeded during use.
 * Concerning the allowable pressure for each temperature, material and actuator type, see the technical documents at the end of this catalog.
 * The diaphragm may become loose due to temperature changes during long storage, operation stop or while in use. Check the conditions and then retighten the bolts and nuts between the bonnet and the body to the "bonnet tightening torque". (Failure to do so may cause fluid leakage.)

AUTOMATIC



DIAPHRAGM VALVE (TYPE AI)



TRUE UNION DIAPHRAGM VALVE (TYPE AI)

COMPATIBLE ACTUATOR **AUTOMATIC**

PNEUMATIC TYPE AI

For detailed specifications, see P.120

PRODUCT MODEL CODE LIST — DIAPHRAGM VALVE (TYPE AI)

ACTUATION	TYPE	ACTUATOR TYPE	ACTION / POWER SOURCE	BODY MATERIAL	SEAL MATERIAL	CONNECTION	STANDARD	SIZE
A	DA	I	*	*	*	F	*	***
A	DA	I	F DOUBLE ACTING (1.0 MPa TYPE) G AIR TO OPEN (0.7 MPa TYPE) H AIR TO OPEN (1.0 MPa TYPE) S AIR TO CLOSE (1.0 MPa TYPE)	U U-PVC C C-PVC P PP F PVDF	E EPDM T PTFE	F FLANGED	1 JIS10K D DIN A ANSI	015 15mm 050 50mm

PRODUCT MODEL CODE LIST — TRUE UNION DIAPHRAGM VALVE (TYPE AI)

ACTUATION	TYPE	ACTUATOR TYPE	ACTION / POWER SOURCE	BODY MATERIAL	SEAL MATERIAL	CONNECTION	STANDARD	SIZE
A	TA	I	*	*	*	*	*	***
A	TA	I	F DOUBLE ACTING (1.0 MPa TYPE) G AIR TO OPEN (0.7 MPa TYPE) H AIR TO OPEN (1.0 MPa TYPE) S AIR TO CLOSE (1.0 MPa TYPE)	U U-PVC C C-PVC P PP F PVDF	E EPDM 1 PTFE+EPDM 2 PTFE+FKM	S SOCKET N THREADED P SPIGOT	J JIS10K D DIN A ANSI	015 15mm 050 50mm

AUTOMATIC PNEUMATIC

TYPE AI

DOUBLE ACTING
AIR TO OPEN
AIR TO CLOSE

DIAPHRAGM VALVE (TYPE AI)

TYPE—ADA1
CONNECTION / FLANGED—JIS, DIN, ANSI

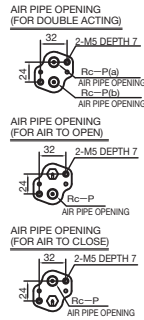
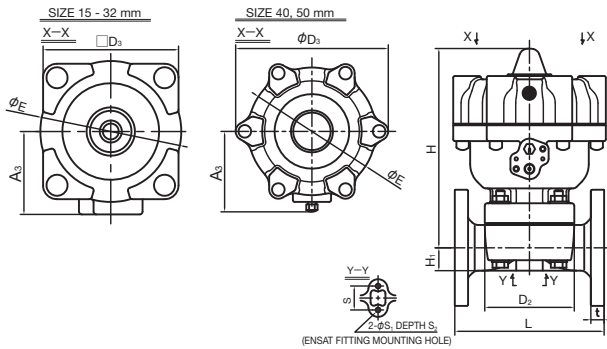

ACTUATOR SELECTION CHART

SIZE	ACTUATOR TYPE				
	DOUBLE ACTING	AIR TO OPEN (0.7 MPa TYPE)	AIR TO OPEN (1.0 MPa TYPE)	AIR TO OPEN (1.0 MPa TYPE)	AIR TO CLOSE
		DIAPHRAGM COMMON	PTFE DIAPHRAGM	EPDM DIAPHRAGM	
15mm (1/2inch)	AI-1DA	AI-1AO	AI-1AO-P	AI-1AO-E	AI-1AS
20mm (3/4inch)	AI-2DA	AI-2AO	AI-2AO-P	AI-2AO-E	AI-2AS
25mm (1inch)					
32mm (1 1/4inch)	AI-3DA	AI-3AO	AI-3AO-P	AI-3AO-E	AI-3AS
40mm (1 1/2inch)	AI-4DA	AI-4AO	AI-4AO-P	AI-4AO-E	AI-4AS
50mm (2inch)	AI-5DA	AI-5AO	AI-5AO-P	AI-5AO-E	AI-5AS

For detailed specifications, see P.120

JIS, DIN (Unit: mm)

mm	D ₂	D ₃	E	H		H ₁	A ₃		S	S ₁	S ₂	P	JIS10K					DIN PN10						
				AIR TO OPEN (0.7MPa)	AIR TO OPEN (1.0MPa)		DOUBLE ACTING	AIR TO OPEN (1.0MPa)					D	C	n	h	L	t	D	C	n	h	t	L
15	54×66	91	94	145	145	19.5	55	67	25	7	13	1/4	95	70	4	15	110	12	95	65	4	14	12	130
20	60×74	91	94	153	153	17.5	55	67	25	7	13	1/4	100	75	4	15	120	13	105	75	4	14	13	150
25	67×80	100	102	161	161	18.5	60	72	25	7	13	1/4	125	90	4	19	130	13	115	85	4	14	13	160
32	67×80	100	102	165	165	22.5	60	72	25	7	13	1/4	135	100	4	19	142	16	140	100	4	18	16	180
40	108×108	184	154	238	238	27.5	85	97	45	9	15	1/4	140	105	4	19	180	16	150	110	4	18	20	200
50	123×123	184	154	254	278	36	85	97	45	9	15	1/4	155	120	4	19	210	20	165	125	4	18	22	230

ANSI (Unit: inch)

inch	mm	D ₂	D ₃	E	H		H ₁	A ₃		S	S ₁	S ₂	P	ANSI			
					AIR TO OPEN (0.7MPa)	AIR TO OPEN (1.0MPa)		DOUBLE ACTING	AIR TO OPEN (1.0MPa)					GRINNELL STANDARD	AV STANDARD	U-PVC C-PVC	PP PVDF
1/2	15	2.13×2.60	3.58	3.70	5.71	5.71	0.77	2.17	2.64	0.98	0.28	0.51	1/4	4.25	4.33	0.43	
3/4	20	2.36×2.91	3.58	3.70	6.02	6.02	0.69	2.17	2.64	0.98	0.28	0.51	1/4	5.88	4.72	0.51	
1	25	2.64×3.15	3.94	4.02	6.34	6.34	0.73	2.36	2.83	0.98	0.28	0.51	1/4	5.88	5.12	0.59	
1 1/4	32	2.64×3.15	3.94	4.02	6.50	6.50	0.89	2.36	2.83	0.98	0.28	0.51	1/4	6.38	-	0.63	
1 1/2	40	4.25×4.25	7.24	6.06	9.37	9.37	1.08	3.35	3.82	1.77	0.35	0.59	1/4	6.94	7.09	0.63	
2	50	4.84×4.84	7.24	6.06	10.00	10.94	1.42	3.35	3.82	1.77	0.35	0.59	1/4	7.94	8.27	0.79	

AUTOMATIC PNEUMATIC

TYPE AI

DOUBLE ACTING
AIR TO OPEN
AIR TO CLOSE

TRUE UNION DIAPHRAGM VALVE (TYPE AI)

TYPE—ATAI
CONNECTION / SOCKET—JIS, DIN, ANSI THREADED—Rc, Rp, NPT

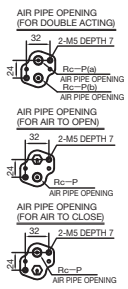
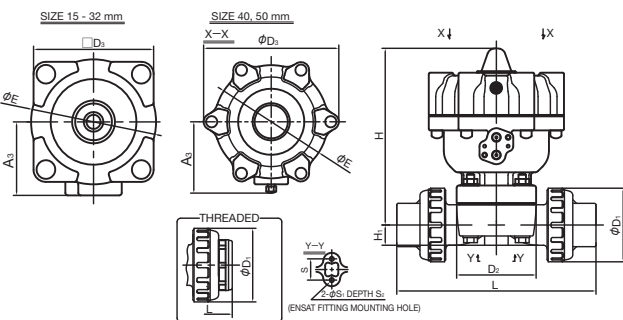

ACTUATOR SELECTION CHART

SIZE	ACTUATOR TYPE				
	DOUBLE ACTING	AIR TO OPEN (0.7 MPa TYPE)	AIR TO OPEN (1.0 MPa TYPE)	AIR TO OPEN (1.0 MPa TYPE)	AIR TO CLOSE
		DIAPHRAGM COMMON	PTFE DIAPHRAGM	EPDM DIAPHRAGM	
15mm (1/2inch)	AI-1DA	AI-1AO	AI-1AO-P	AI-1AO-E	AI-1AS
20mm (3/4inch)	AI-2DA	AI-2AO	AI-2AO-P	AI-2AO-E	AI-2AS
25mm (1inch)					
32mm (1 1/4inch)	AI-3DA	AI-3AO	AI-3AO-P	AI-3AO-E	AI-3AS
40mm (1 1/2inch)	AI-4DA	AI-4AO	AI-4AO-P	AI-4AO-E	AI-4AS
50mm (2inch)	AI-5DA	AI-5AO	AI-5AO-P	AI-5AO-E	AI-5AS

For detailed specifications, see P.120

JIS, DIN (Unit: mm)

mm	D ₁	D ₂	D ₃	E	H		H ₁	A ₃		S	S ₁	S ₂	P	JIS		DIN									
					AIR TO OPEN (0.7MPa)	AIR TO OPEN (1.0MPa)		SOCKET	THREADED					SOCKET	THREADED	SPIGOT									
														U-PVC C-PVC	PP PVDF	U-PVC C-PVC	PP PVDF	U-PVC C-PVC	PP PVDF	U-PVC C-PVC	PP PVDF	PP	PVDF	PP	PVDF
15	48	54×66	91	94	145	145	19.5	55	67	25	7	13	1/4	134	128	128	128	125	128	148	150	150	2.5	1.9	
20	60	60×74	91	94	153	153	17.5	55	67	25	7	13	1/4	156	148	148	148	141	148	148	172	172	2.7	1.9	
25	70	67×80	100	102	161	161	18.5	60	72	25	7	13	1/4	186	172	172	172	164	172	172	195	195	3.0	2.4	
32	82	67×80	100	102	165	165	22.5	60	72	25	7	13	1/4	200	188	188	188	177	188	188	212	212	3.7	2.4	
40	100	108×108	184	154	238	238	27.5	85	97	45	9	15	1/4	271	245	245	246	231	245	245	276	276	4.6	3.0	
50	106	123×123	184	154	254	278	36	85	97	45	9	15	1/4	303	281	278	294	274	281	278	308	307	5.8	3.0	

ANSI (Unit: inch)

inch	mm	D ₁	D ₂	D ₃	E	H		H ₁	A ₃		S	S ₁	S ₂	P	ANSI			
						AIR TO OPEN (0.7MPa)	AIR TO OPEN (1.0MPa)		SOCKET	THREADED					SOCKET	THREADED	PP PVDF	PP PVDF
1/2	15	1.89	2.13×2.60	3.58	3.70	5.71	0.77	2.17	2.64	0.98	0.28	0.51	1/4	5.47	5.43	5.04	5.04	
3/4	20	2.36	2.36×2.91	3.58	3.70	6.02	0.69	2.17	2.64	0.98	0.28	0.51	1/4	6.18	6.09	5.83	5.83	
1	25	2.76	2.64×3.15	3.94	4.02	6.34	0.73	2.36	2.83	0.98	0.28	0.51	1/4	7.32	7.24	6.77	6.77	
1 1/4	32	3.23	2.64×3.15	3.94	4.02	6.50	0.89	2.36	2.83	0.98	0.28	0.51	1/4	7.95	7.80	7.40	7.40	
1 1/2	40	3.94	4.25×4.25	7.24	6.06	9.37	1.08	3.35	3.82	1.77	0.35	0.59	1/4	10.47	10.28	9.65	9.65	
2	50	4.17	4.84×4.84	7.24	6.06	10.00	1.42	3.35	3.82	1.77	0.35	0.59	1/4	11.54	11.54	11.06	10.95	

DIAPHRAGM VALVE TYPE 16

- NEAR-LINEAR FLOW CHARACTERISTICS
- COMPACT BODY ALLOWS FOR INSTALLATION IN LIMITED PIPING SPACE.
- EXCELLENT OPEN/CLOSE DURABILITY TO WITHSTAND MORE THAN 1,000,000 CYCLES OF OPENING AND CLOSING
- ALL-PLASTIC BODY ENSURES EXCELLENT CORROSION RESISTANCE.

BASIC SPECIFICATIONS

VALVE TYPE ————— **DIAPHRAGM VALVE TYPE 16**

SIZE ————— **15 mm—50 mm (1/2 inch—2 inch)**

BODY MATERIAL ————— **U-PVC**

SEAL MATERIAL / DIAPHRAGM ————— **EPDM** **PTFE**

O-RING ————— **EPDM** **FKM**

CONNECTION / FLANGED ————— **JIS10K, DIN PN10, ANSI CLASS150**

SOCKET ————— **JIS, DIN, ANSI**

THREADED ————— **Rc, Rp, NPT**

	FLUID TEMPERATURE	MAXIMUM WORKING PRESSURE (NORMAL TEMPERATURE) MPa(kgf/cm ²)		CONNECTION METHOD		
		15 mm - 25 mm	40 mm, 50 mm	FLANGED	SOCKET	THREADED
U-PVC	0°C ~ 50°C	0.5 {5.1}	0.4 {4.1}	○	○	○

NOTE The maximum working pressure is the value including the water hammer pressure. Be careful that the maximum working pressure is not exceeded during use.
 * Concerning the allowable pressure for each temperature and material, see the technical documents at the end of this catalog.



COMPATIBLE ACTUATOR **AUTOMATIC**

PNEUMATIC **TYPE AD** For detailed specifications, see P.121

PRODUCT MODEL CODE LIST	ACTUATION	TYPE	ACTION / POWER SOURCE	BODY MATERIAL	SEAL MATERIAL	CONNECTION	SIZE	LUB. FREE	OPERATION PORT DIRECTION	OPTION
AUTOMATIC	A	16	**	U	*	**	***	1	*	*

A AUTOMATIC VALVE

16 TYPE 16

DF DOUBLE ACTING
DG AIR TO OPEN

U U-PVC

1 PTFE/EPDM
2 PTFE/FKM
E EPDM/EPDM

015 15mm
050 50mm

1

- SJ SOCKET, JIS
- S8 SOCKET, ASTM SCH80
- SD SOCKET, DIN
- NJ THREADED, Rc
- NA THREADED, NPT
- ND THREADED, Rp
- F1 FLANGED, 10K
- FA FLANGED, ANSI
- FD FLANGED, DIN

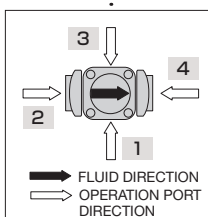

- 1 NONE
- 2 SPEED CONTROLLER
- 3 FULL OPENING ADJUSTMENT
- 4 FULL OPENING ADJUSTMENT / SPEED CONTROLLER
- 5* FULL OPENING ADJUSTMENT / INDICATOR
- 6* FULL OPENING ADJUSTMENT / INDICATOR / SPEED CONTROLLER

* Only applicable for sizes of 15 mm to 25 mm.

AUTOMATIC

PNEUMATIC

TYPE AD

DOUBLE ACTING

AIR TO OPEN

AIR TO CLOSE

DIAPHRAGM VALVE TYPE 16

TYPE—A16D

CONNECTION / FLANGED, SOCKET, THREADED—JIS, DIN, ANSI

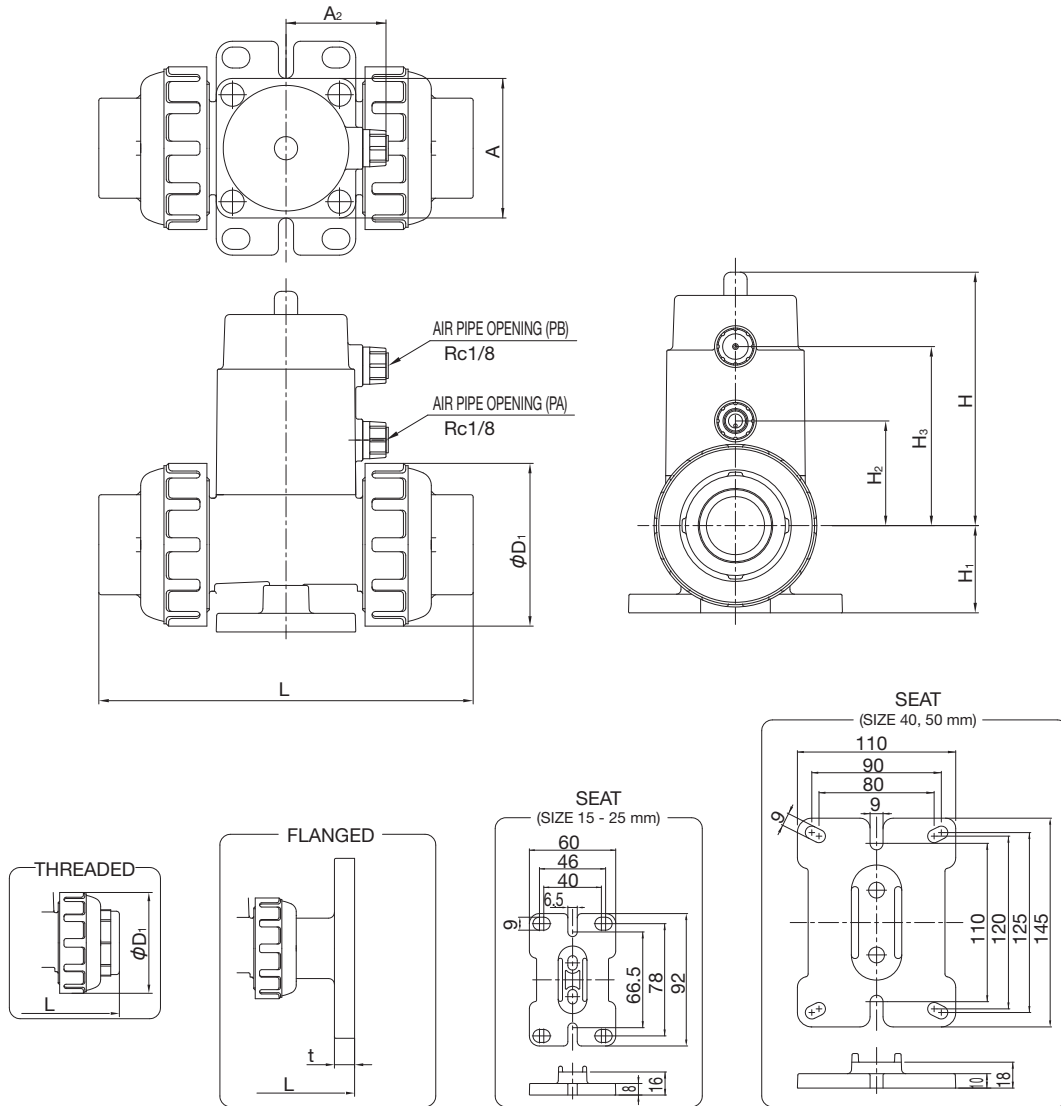

■ JIS, DIN (Unit: mm)

mm	D ₁	H	H ₁	H ₂	H ₃	A	A ₂	JIS			DIN				
								FLANGED JIS10K L	SOCKET L	THREADED L	FLANGED PN10 L	SOCKET L	THREADED L		
15	48	79.0	33.0	33	60	□50	38	158	12	124.4	117.0	145	12	117	117
20	60	108.0	36.5	44	76	□60	43	191	14	147.0	139.0	169	14	138	139
25	70	109.0	37.5	45	77	□60	43	205.5	14	163.5	149.5	178.5	14	149.5	149.5
40	100	161.5	53.0	68	115	□95	60	264	16	241.0	215.0	252	16	216	215
50	126	188.5	66.0	83	137	□115	70.5	297	16	283.0	260.0	293	16	260	260

■ ANSI (Unit: inch)

inch	mm	D ₁	H	H ₁	H ₂	H ₃	A	A ₂	ANSI			
									FLANGED L	SOCKET L	THREADED L	
1/2	15	1.89	3.11	1.30	1.30	2.36	1.97	1.49	6.22	0.47	5.04	4.61
3/4	20	2.36	4.25	1.44	1.73	2.99	2.36	1.69	7.52	0.55	5.83	5.47
1	25	2.76	4.29	1.48	1.77	3.03	2.36	1.69	8.09	0.55	6.44	5.89
1 1/2	40	3.94	6.36	2.09	2.68	4.53	3.74	2.36	10.39	0.63	9.29	8.46
2	50	4.96	7.42	2.60	3.27	5.39	4.53	2.77	11.69	0.63	10.71	10.24

OPTIONS

In addition to the standard product lines described on the previous pages, the following options are also available according to your requirements:

1 PVDF Cushion Cover Model

For corrosive fluid transport lines, we offer PVDF cushion cover accessories having excellent gas barrier performance to prevent deterioration due to permeation of gas from the diaphragm.

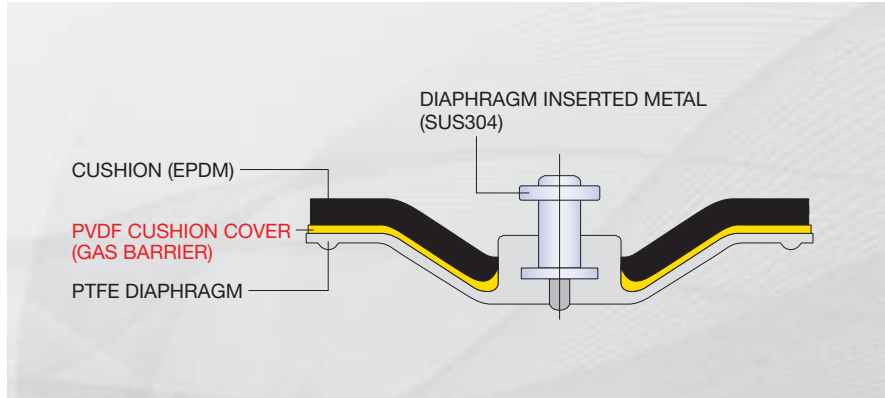

2 Electrolytic Model

For chlorine gas lines in electrolysis plants, we offer electrolytic options using highly corrosion resistant special metal to prevent corrosion of embedded diaphragm fittings.

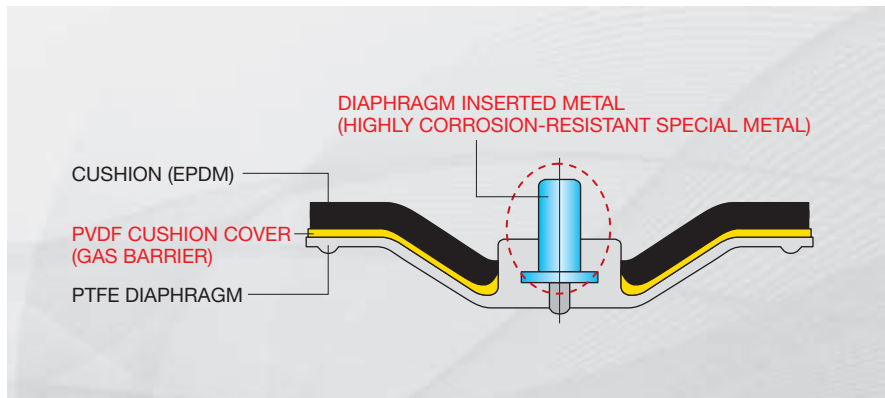

3 EL Model

For lines in harsher conditions, we offer EL Model comprising a main body (EL-PVDF) made of special materials and a PTFE diaphragm (EL-PTFE).

<Size>

15 - 100 mm: Standard model applicable
 125 - 250 mm: Made-to-order

* For details, contact our sales office in your area.

<Field test result>

- Soda electrolysis plant / returned brine
- 88°C, 0.3 MPa, used for 5 years

[EL-PVDF]
Without blister



[PVDF]
With blister

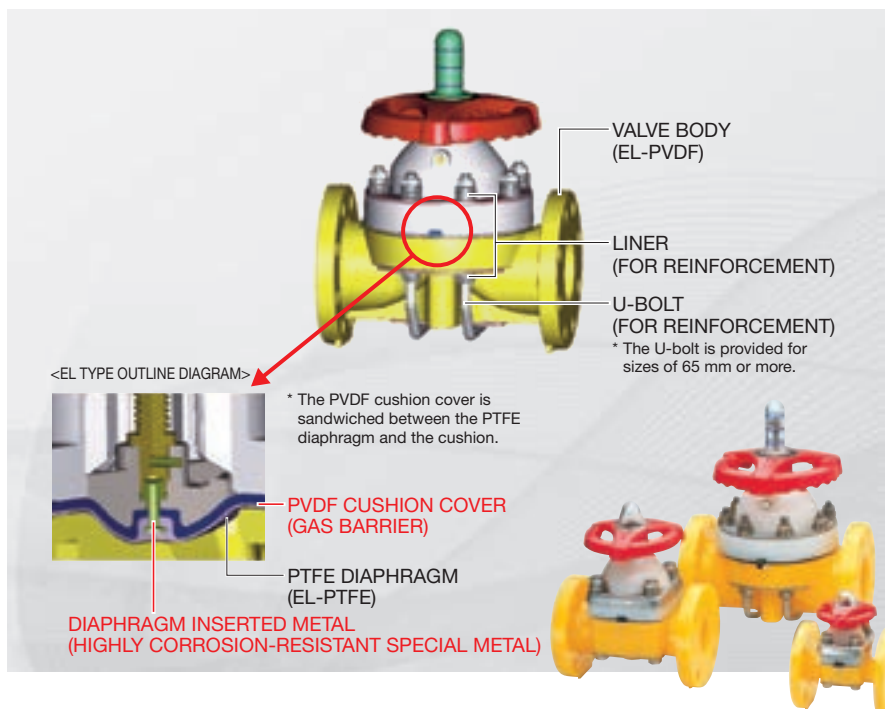

4 MODEL A AND MODEL B

Diaphragm valve type 72 (size: 200 mm, 250 mm) can be divided into Model A and Model B.

Model A is the standard type. Normally, select Model A.

Select Model B when Model A cannot be used due to the relationship between the working temperature and pressure.

	MODEL A (STANDARD)	MODEL B (OPTION)
BODY MATERIAL: U-PVC	<p>DIAPHRAGM MATERIAL: RUBBER AND PTFE</p>	<p>DIAPHRAGM MATERIAL: RUBBER AND PTFE</p>
BODY MATERIAL: PP	<p>DIAPHRAGM MATERIAL: RUBBER AND PTFE</p>	<p>DIAPHRAGM MATERIAL: RUBBER AND PTFE</p>
BODY MATERIAL: PVDF	<p>DIAPHRAGM MATERIAL: RUBBER AND PTFE</p>	<p>DIAPHRAGM MATERIAL: PTFE</p>